



**OLFA**<sup>®</sup>

# KATALOG Br. 201

Do novih poslovnih dostignuća  
zahvaljujući beskrajnim idejama OLFA korporacije

# Kao Tvorci

nožića za sečenje koji se lome,  
obavezali smo se da razvijamo i unapređujemo  
jedinственe i sigurne proizvode.

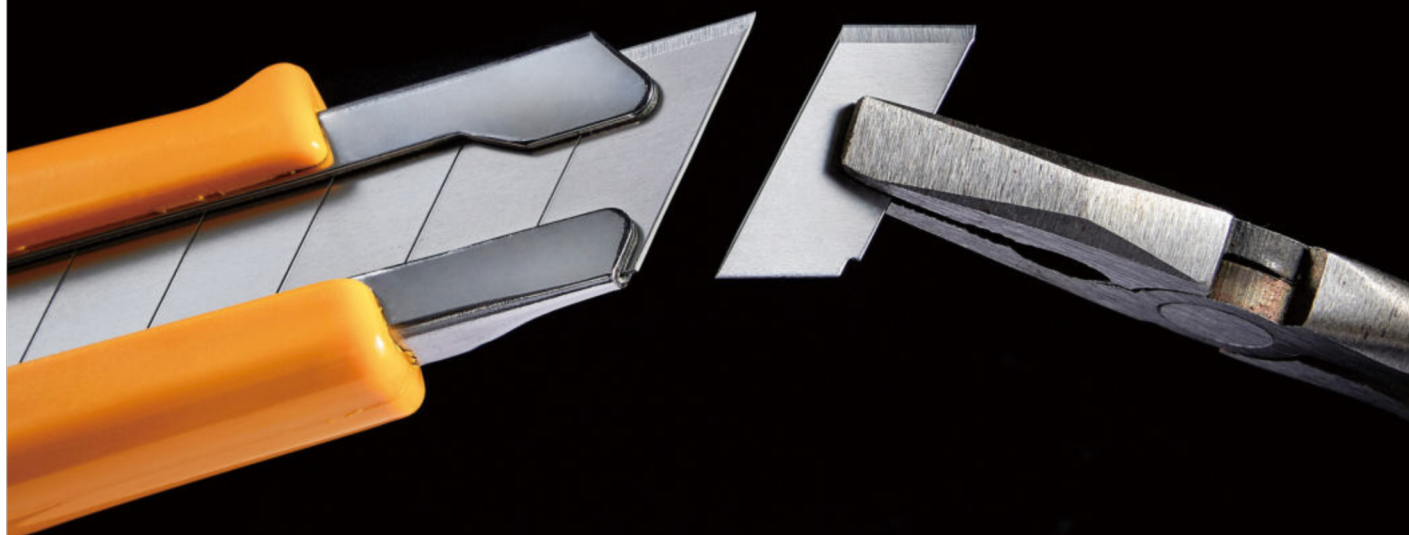

**1956**

Prvi na svetu proizveden  
skalpel sa nožićem koji se lomi



**1979**

Prvi na svetu proizveden  
rotacioni skalpel



Od 1956 od kada je OLFA izumela prvi skalpel sa nožićem koji se lomi, OLFA je napravila proizvod kao što je Rotacioni skalpel koji seče tkaninu rolajući rotacioni nožić. Danas, OLFA je broj 1 u Japanu za proizvodnju skalpela i nožića, i izvozi za korisnike koji cene kvalitet u preko 100 zemalja na svetu.



Osnivač  
OLFA KORPORACIJE

Mr. Yoshio OKADA  
(1931 - 1990)



OLFA  
RUČICA

za  
vaše  
**RUKE**

made in  
Japan



Sa pola veka težnje za  
što udobniju ručicu i veću oštrinu nožića,  
naš rezultat isporučujemo u ruke korisnika za različite poslove.



# POWER OF X



KLIP  
POWER  
OF X





## X-design Serija



Napravljeni sa gumiranom ručicom  
da bi se sprečilo proklizavanje pružajući dobru stabilnost.

X-Design serija nastoji da pruži najbolje držanje i stabilnost prilikom sečenja.



Extra Heavy-Duty  
Modeli

**XH-1**



Heavy-Duty  
Modeli

**L-5**



Modeli Srednje  
veličine

**XMT-1**



Standardni  
Modeli

**XA-1**



Strugači

**XSR-200**







OLFA predlog za stvaranje sigurnijeg radnog okruženja

# SAFETY

Sigurnost na prvom mestu

# FIRST

™

Bezbednost radnika je prioritet

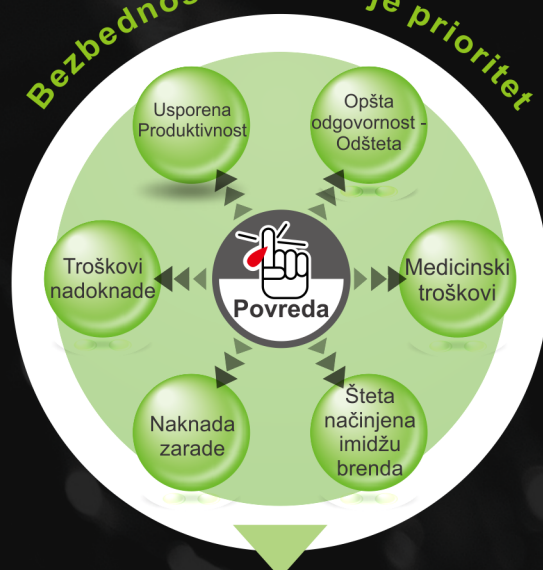

Mogućnosti štete u Vašoj kompaniji.

Mi u OLFA korporaciji želeli bi da podržimo poboljšanje sigurnosti u vašoj kompaniji.

Naša SK serija dizajnirana je da bude sigurna pri korišćenju i idealna je za profesionalnu upotrebu.



SK-4



SK-4/HOK



SK-5



SK-6



SK-7



SK-8



SK-9



SK-10



SK-12



SK-15



SK-16



40+ godina ranije,

OLFA je napravila prvi rotacioni skalpel  
i napravila revoluciju u načinu sečenja tkanine.



∞ Izdržljiv nožić  
∞ ENDURANCE™ BLADE



Kompaktan sigurnosni skalpel sa nožićima koji se lome

Za početnike

# ESK-1 PAT.

Tri laka koraka!

Iseci!



Odlomi!



Odloži!



Nožić sa 4 segmenta



Simetrični dizajn.  
Samo rotirati nožić za upotrebu  
levom ili desnom rukom.



Plastični prekrivač nožića  
minimalizuje njegovu izloženost  
radi bolje bezbednosti.

※ Koristiti namensku kutiju za odlaganje  
nožića prilikom odlamanja segmenata.



UPUTSTVO ZA UPOTREBU  
ESK-1

[www.olfa.co.jp/en/manual](http://www.olfa.co.jp/en/manual)

U OLFA kropsoraciji, obezbeđujemo ekološke proizvode i jednostavna pakovanja za različite potrebe.



Ekološki skalpeli napravljeni od recikliranih materijala. Jednaka izdržljivost i oštrina nožića kao i kod originalnih verzija.



L-1/green  
→p.13



ES-1/green  
→p.24



SK-4/green  
→p.28



SK-7/green  
→p.29



## Industrijsko Pakovanje



SK-4/24

→p.28



SK-15/10

→p.27



SK-7/24

→p.29



SK-8/24

→p.29



SK-9/32

→p.30



SK-10/24

→p.30



SK-12/24

→p.31

**L-5**

BROJ MODELA

NUMÉRO DU MODÈLE | MODELL NUMMER | NUMERO DE MODELO

LBB/LB/LBD/LB-SOL/  
LFB/LWB

220×95×25 (mm)

6×20 (pcs.)

**Ugrađeno tvrdo metalno kućište za višenamensku upotrebu**

- Conception-X, force de coupe supérieure. Pointe en métal dur intégrée pour applications polyvalentes
- X-Design, bessere Schneidekraft. Eingebaute Hartmetall-Picke für Mehrzweckanwendung
- Diseño X, fuerza de corte superior. Clip metálico duro integrado para las aplicaciones multiuso

**Zaključavanje nožića točkićem**

- VERROUILLAGE POSITIF PAR MOLETTE
- POSITIVE RADVERRIEGELUNG
- BLOQUEO POSITIVO A RUEDECILLA

**Automatsko zaključavanje nožića**

- VERROUILLAGE AUTOMATIQUE
- AUTO-LOCK KLINGENFESTSTELLER
- BLOQUEO AUTOMATICO

**Nožić od nerđajućeg čelika**

- LAME ACIER INOXIDABLE
- KLINGE AUS ROSTFREIEM
- CUCHILLA DE ACERO INOXIDABLE

**Otporan na kiselinu i aceton**

- RÉSISTANT À L'ACIDE ET À L'ACÉTONE
- SÄURE UND AZETON BESTÄNDIG
- RESISTENTE AL ÁCIDO Y A LA ACETONA

**ULTRA oštar nožić**

- LAME ULTRA AIGUISÉE
- ULTRA-SHARFE KLINGE
- CUCHILLA ULTRA AFILADA

**Za levoruke i desnoruke**

- POUR UTILISATEURS GAUCHERS ET DROITIERS
- FÜR RECHTS- UND LINKSHÄNDER
- PARA USUARIOS DIESTROS Y ZURDOS

**Nožić sa jednom oštrom stranom**

- LAME AVEC UN SEUL CÔTÉ AFFÛTÉ
- EINSEITIG GESCHÄRFTE KLINGE
- CUCHILLA DE FILO ÚNICO

**Patentiran**

- BREVETÉ
- PATENTADO
- PATENTIERT

**Patent na čekanju**

- EN ATTENTE DE BREVET
- PATENTE PENDIENTE
- ANGEMELDETES PATENT

**Ručica napravljena od recikliranog mat.**

- MANCHE COMPOSÉ À DE PLASTIQUE RECYCLÉS.
- HANDGEFERTIGT AUS RECYCELTEM MATERIAL.
- HECHO A MANO CON PLÁSTICO RECICLADO.

[www.certipedia.com](http://www.certipedia.com)

GS (Geprüfte Sicherheit) oznaka na OLFA proizvodima po Nemačkom zakonu o sigurnosti garantuje "kvalitet/sigurnost" GS oznaka je poznata kao sigurnosna oznaka ne samo u Nemačkoj već i u celom svetu.

- Les produits de la marque GS (Geprüfte Sicherheit) sont approuvés par les normes allemandes de «Qualité/Sécurité».
- La marque GS est reconnue en tant que de conformité de référence non seulement en Allemagne mais aussi dans le reste du monde.
- Mit GS (Geprüfte Sicherheit) ausgezeichnete Produkte sind für „Qualität/Sicherheit“ unter deutschen Produktsicherheitsgesetzen anerkannt. Die GS-Kennzeichnung ist nicht nur in Deutschland als Sicherheitszertifikat bekannt, sondern auf der ganzen Welt.
- Los productos con la marca GS (Geprüfte Sicherheit) han sido aprobados por su "Calidad/Seguridad" según las leyes alemanas de seguridad en productos. La marca GS es reconocida como un certificado de seguridad no sólo en Alemania sino también en el resto del mundo.



NSF sertifikati je osiguranje da proizvod zadovoljava striktno standarde svetske zdravstvene organizacije. Američki Nacionalni Institut za standardizaciju prihvata NSF sertifikati.

- La certification NSF est essentielle pour s'assurer que les produits satisfont des normes strictes pour la protection de la santé publique. L'Institut national de normalisation américain applique les certifications NSF.
- Die NSF-Zertifizierung ist entscheidend, um sicherzustellen, dass die Produkte die strengen Standards für den Schutz der öffentlichen Gesundheit erfüllen. Das American National Standards Institute wendet die NSF-Zertifizierungen an.
- La certificación NSF es la clave para cerciorarse de que los productos cumplen los estrictos estándares para la protección de la salud pública. El Instituto de Estándares Nacionales Americanos aplica las certificaciones NSF.

**ZAMENSKI NOŽIĆ**

- LAMES DE RECHANGE
- ERSATZKLINGEN
- CUCHILLAS DE REPUESTO

**PAKOVANJE**

- EMBALLAGE
- VERPACKUNG
- EMBALAJE

**PAKOVANJA U KUTIJI**

- CONTENU DE CARTON
- KARTONINHÄLF
- CONTENIDO DE EMBALAJE

**SADRŽAJ**

- SOMMAIRE
- INHALT
- TABLA DE CONTENIDO

**Extra Heavy-Duty Modeli**  
► P11

25mm

**Heavy-Duty Modeli**  
► P12~18

18mm

**Modeli srednje veličine**  
► P19~20

12.5mm

**Standardni modeli**  
► P21~24

9mm

**Kutije za odlaganje nožića**  
► P25

**Makaze**  
► P26

**Sigurnosni modeli**  
► P27~31

**Strugači**  
► P32~34

**Rotacioni skalpeli i lenjiri**  
► P35~41

**Art&Hobby - Ručni alati za razne namene**  
► P42~47

**Podloge za sečenje**  
► P48~52

**Stalci za izlaganje - Štenderi**  
► P53

**Rezervni nožići**  
► P54~58



# Extra Heavy-Duty Modeli

25 mm

Sa nožićem od 25mm ovi modeli su najprikladniji za profesionalnu upotrebu.

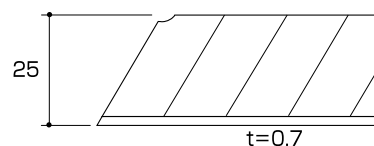

## Modèles supplémentaires pour gros travaux

Avec la lame de 25 mm, les cutters supplémentaires pour les gros travaux sont plus appropriés pour les environnements de travail professionnels.

## Extra Stabile Modelle

Mit der 25-mm-Klinge sind die Cutter für schwere Arbeiten passend für professionelle Arbeitsplätze.

## Modelos de trabajo pesado extra

Con una cuchilla de 25 mm, los cortadores de uso industrial son más apropiados para entornos de trabajo profesionales.

Extra Heavy-Duty Modeli Heavy-Duty Modeli

### XH-1



HBB/HB/HSWB-1 220x95x28.6 (mm) 6x12 (pcs.)

X-Dizajn, superiorna snaga sečenja

- Conception-X, force de coupe supérieure
- X-Design, bessere Schneidekraft
- Diseño X, fuerza de corte superior



### XH-AL



HBB/HB/HSWB-1 220x95x27 (mm) 6x12 (pcs.)

X-Dizajn, superiorna snaga sečenja

- Conception-X, force de coupe supérieure
- X-Design, bessere Schneidekraft
- Diseño X, fuerza de corte superior



### NH-1



HB/HBB/HSWB-1 220x115x34 (mm) 6x12 (pcs.)

Ručica od elastomera protiv proklizavanja

- Poignée en élastomère antidérapante
- Rutschfester Elastomergriff
- Mango de elastómero antideslizante



### H-1



HB/HBB/HSWB-1 220x95x26.9 (mm) 6x12 (pcs.)

Sa velikim gumenim jastučićem protiv proklizavanja.

- Avec un grand tampon en caoutchouc
- Mit großer Unterplatte
- Con almohadilla de caucho de gran tamaño



### HSW-1



HSWB-1/HB/HBB 228x92x25 (mm) 6x12 (pcs.)

H-1 model sa testerom od 25mm

- Compact, avec une nouvelle lame scie de 25 mm
- Kompakt, mit einer neuen 25-mm-SÄGE-Klinge
- Compacta, con una nueva cuchilla SAW de 25 mm

HSWB-1 model donosi perfektnu kombinaciju tvrdoće i oštine. Proces impulsnog kaljenja u mnogome produžava vek nožića (testere).

Elektrolitska Niklovana oplata na nožiću povećava trajnost i otpornost na koroziju.

- La lame HSWB-1 offre une association optimale de robustesse et d'affûtage. Le processus de durcissement par impulsion améliore la durée de vie de la lame. Le placage auto catalytique au nickel de la lame améliore la durabilité et la résistance à la corrosion.
- Die Klinge HSWB-1 bietet die ultimative Kombination aus Robustheit und Schärfe. Der Impulshärtungsprozess erhöht die Lebensdauer der Klinge. Die chemische Vernickelung auf der Klinge sorgt für zusätzliche Haltbarkeit und Korrosionsbeständigkeit.
- La cuchilla HSWB-1 ofrece la mejor combinación de rigidez y afilado. El proceso de endurecimiento por pulsos alarga la vida útil de la cuchilla. El chapado de níquel químico de la cuchilla proporciona una mayor durabilidad y resistencia a la corrosión.



# Heavy-Duty Modeli

Ovi modeli sa nožićem od 18mm mogu se koristiti raznovrsne poslove sečenja.

**18**  
mm

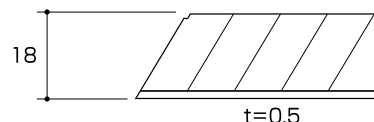

## Modèles pour gros travaux

Avec la lame de 18 mm, les poignées robustes sont particulièrement adaptées pour les travaux de coupe polyvalents.

## Stabile Modelle

Mit der 18-mm-Klinge sind die Griffe für schwere Arbeiten am besten für vielseitige Schneidarbeiten geeignet.

## Modelos de uso industrial

Con una cuchilla de 18 mm, las asas de uso industrial son las mejores para las tareas de corte versátiles.

### MXP-L



LBB/LB/LBD/  
LB-SOL/LFB/LWB

220×95×29 (mm)

6×10 (pcs.)

X-Dizajn, superiorna snaga sečenja.  
Kvalitetno izliveno aluminijumsko telo.  
Tvrđ kanal nožića zahvaljujući kaljenju celokupne površine tela skalpela.  
Ugrađen čvrst metalni toččić za kočenje nožića.

Aluminium moulé sous pression. Corps moulé sous pression en aluminium solide.  
La conception globale du cutter rend le guide lame extrêmement robuste.  
Verrouillage de roue solidement construit en métal monobloc.

Griff aus Aluminium Druckguss. Solider Griff aus Aluminium Druckguss.  
Stabile und präzise Klingenföhrung im Aluminiumgriff.  
Robust gebautes, einteiliges Metallradschloss.

Cuerpo de aluminio fundido. Cuerpo robusto fabricado en fundición de aluminio.  
Guía de la cuchilla de gran robustez debido al endurecimiento de toda la superficie.  
Cerradura de rueda metálica de una sola pieza de construcción sólida.



### MXP-AL



LBB/LB/LBD/LB-SOL/  
LFB/LWB

220×95×29 (mm)

6×10 (pcs.)

X-Dizajn, superiorna snaga sečenja.  
Kvalitetno izliveno aluminijumsko telo.  
Tvrđ kanal nožića zahvaljujući kaljenju celokupne površine tela skalpela.  
Tanka automatska kočnica nožića dizajnirana specijalno za ovaj model.

Aluminium moulé sous pression.  
Corps moulé sous pression en aluminium solide.  
La conception globale du cutter rend le guide lame extrêmement robuste.  
Glissière mince autobloquante spécifiquement conçue pour ce modèle.

Griff aus Aluminium Druckguss.  
Solider Griff aus Aluminium Druckguss.  
Stabile und präzise Klingenföhrung im Aluminiumgriff.

Schlanker und automatisch schließender Schieber, der speziell für dieses Modell entwickelt wurde.

Cuerpo de aluminio fundido.  
Cuerpo robusto fabricado en fundición de aluminio.  
Guía de la cuchilla de gran robustez debido al endurecimiento de toda la superficie.  
Pulsador autobloqueante delgado diseñado específicamente para este modelo.



### L-5



LBB/LB/LBD/LB-SOL/  
LFB/LWB

220×95×25 (mm)

6×20 (pcs.)

Ugrađen čvrst jezičak u kućište za višenamensku primenu.

Conception-X, force de coupe supérieure  
Pointe en métal dur intégrée pour applications polyvalentes

X-Design, bessere Schneidekraft  
Eingebaute Hartmetall-Picke für Mehrzweckanwendung

Diseño X, fuerza de corte superior  
Clip metálico duro integrado para las aplicaciones multiuso



### L5-AL



LBB/LB/LBD/LB-SOL/  
LFB/LWB

220×95×25 (mm)

6×20 (pcs.)

Ugrađen čvrst jezičak u kućište za višenamensku primenu.

Conception-X, force de coupe supérieure  
Pointe en métal dur intégrée pour applications polyvalentes

X-Design, bessere Schneidekraft  
Eingebaute Hartmetall-Picke für Mehrzweckanwendung

Diseño X, fuerza de corte superior  
Clip metálico duro integrado para las aplicaciones multiuso



## L-7



LBB/LB/LBD/  
LB-SOL/LFB/LWB

220×95×28.4 (mm)

6×20 (pcs.)

X-Dizajn ručice sa rupom za kačenje. Pri radu na visini, zbog bezbednosti najbolje je držati ga zakačenog.

Les poignées de conception x sont fournies avec un passage de dragonne intégré. Optimisées pour une utilisation à des endroits en hauteur avec une lanière de sécurité. Type économique.

X-Design-Griffe verfügen über eine eingebaute Bandöse. Am besten geeignet für die Verwendung in Überkopfhaltungen mit einem Sicherheits-Halteband. Ökonomischer Typ.

Las asas con diseño enxmanijas vienen con un orificio para cordón incorporado. Más adecuado para utilizar en ubicaciones por encima de la cabeza, con un cordón de seguridad. Tipo económico.



## L7-AL



LBB/LB/LBD/  
LB-SOL/LFB/LWB

220×95×26 (mm)

6×20 (pcs.)

X-Dizajn ručice sa rupom za kačenje. Pri radu na visini, zbog bezbednosti najbolje je držati ga zakačenog.

Les poignées de conception x sont fournies avec un passage de dragonne intégré. Optimisées pour une utilisation à des endroits en hauteur avec une lanière de sécurité. Type économique.

X-Design-Griffe verfügen über eine eingebaute Bandöse. Am besten geeignet für die Verwendung in Überkopfhaltungen mit einem Sicherheits-Halteband. Ökonomischer Typ.

Las asas con diseño enxmanijas vienen con un orificio para cordón incorporado. Más adecuado para utilizar en ubicaciones por encima de la cabeza, con un cordón de seguridad. Tipo económico.

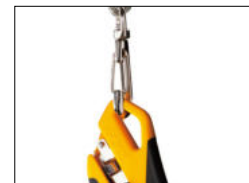

## L-1



LB/LBB/LBD/  
LB-SOL/LFB/LWB

220×80×24 (mm)

6×20 (pcs.)

Najbolji i najprodavaniji model

- | Modèle le plus vendu depuis longtemps
- | Das beste und am längsten verkaufte Modell
- | El modelo de mayor y mejor venta

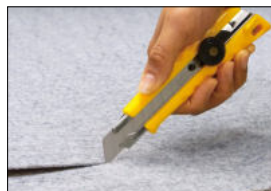

## L-1/green



LB/LBB/LBD/  
LB-SOL/LFB/LWB

220×80×24 (mm)

6×20 (pcs.)

Ekološka verzija najprodavanijeg modela

- | Version écologique du produit phare
- | Öko-Version des Bestsellers
- | Versión ecológica del más vendido





## LTD-L-LFB



LFB/LB/LBB/LBD/  
LB-SOL/LWB



220×95×26.5 (mm)



6×10 (pcs.)

Sa našim LFB nožičem sa visokim performansama za glatko sečenje bez napora.

- Pré-chargé avec une lame LFB à haute performance pour des coupes régulières et sans effort
- Enthält eine unserer leistungsstarken LFB-Klingen für glatte und mühelose Schnitte
- Precargado con nuestra cuchilla LFB de alto rendimiento para cortes suaves y sin esfuerzo



## LTD-AL-LFB



LFB/LB/LBB/LBD/  
LB-SOL/LWB



220×95×24.5 (mm)



6×10 (pcs.)

Sa našim LFB nožičem sa visokim performansama za glatko sečenje bez napora.

- Pré-chargé avec une lame LFB à haute performance pour des coupes régulières et sans effort
- Enthält eine unserer leistungsstarken LFB-Klingen für glatte und mühelose Schnitte
- Precargado con nuestra cuchilla LFB de alto rendimiento para cortes suaves y sin esfuerzo



25mm

18mm

12.5mm

9mm

## SPEED BLADE®

LFB-5B

«Speed Blade» seče karton 2 puta brže od običnog nožića!

Površina presvučena Fluorom drastično smanjuje otpor prilikom sečenja.

- Surface de coupe revêtue de fluorose. La surface en fluorose revêtue réduit la résistance de coupe de manière drastique pendant la coupe d'un carton.
- Fluorbeschichtete Schneidfläche. Die fluoridbeschichtete Oberfläche reduziert den Schneidewiderstand beim Schneiden durch einen Karton drastisch.
- Superficie de corte revestida con flúor. La superficie recubierta por fluorosis reduce la resistencia al corte drásticamente al cortar cartón.

SMANJUJE  
OTPOR  
50%  
u poređenju sa LBB

LFB



18  
mm



Premaz-  
Fluora

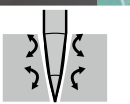

EXCEL BLACK  
ULTRA SHARP BLADES



## L-2



LB/LBB/LBD/  
LB-SOL/LFB/LWB

220×80×28.3 (mm)

6×20 (pcs.)

Sa velikim gumenim jastučićem protiv proklizavanja.

- | Avec un large tampon en caoutchouc
- | Mit großer Unterplatte
- | Con almohadilla de caucho de gran tamaño



## L-3



LB/LBB/LBD/LFB

220×80×24.8 (mm)

6×20 (pcs.)

I za fina i za ozbiljnija sečenja.

- | Pour une découpe à la fois fine et difficile
- | Sowohl für grobes als auch für feines Schneiden
- | Tanto para cortes precisos como para cortes difíciles

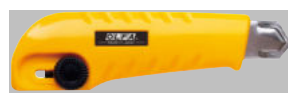

## BN-L



LB/LBB/LBD/  
LB-SOL/LFB/LWB

220×80×25.4 (mm)

6×20 (pcs.)

Svestran model sa ergonomskim dizajnom.

- | Modèle polyvalent à la conception ergonomique
- | Vielfältiges Modell im ergonomischen Design
- | Modelo versátil de diseño ergonómico



## BN-AL



LB/LBB/LBD/  
LB-SOL/LFB/LWB

220×80×25 (mm)

6×20 (pcs.)

Svestran model sa ergonomskim dizajnom.

- | Modèle polyvalent à la conception ergonomique
- | Vielfältiges Modell im ergonomischen Design
- | Modelo versátil de diseño ergonómico



## DL-1



LB/LBB/LBD/LFB

220×95×24 (mm)

6×20 (pcs.)

Sa skladištem za lomljenje i čuvanje istupljenih segmenata nožića koji se skida.

- Avec casse-lame/boite de lames usagées
- Mit Klingenschnapper/Entsorgungsbehälter
- Con desglosador de cuchillas/ estuche para descartar

With detachable blade snapper/disposal case



## PL-1



LB/LBB/LBD/  
LB-SOL/LFB/LWB

222×113×27 (mm)

6×20 (pcs.)

Automatsko uzimanje nožića iz skladišta (do 6 nožića).

- Chargement automatique jusqu'à 6 lames
- Automatisches Laden mit bis zu 6 Klängen
- Carga automática de hasta 6 cuchillas



## NOL-1



LB/LBB/LBD/  
LB-SOL/LFB/LWB

220×80×29.2 (mm)

6×20 (pcs.)

Neklizajuća ručica od Elastomera.

- Poignée en élastomère antidérapante
- Rutschfester Elastomergriff
- Mango de elastómero antideslizante

Anti-Slip elastomer handle



## NL-AL



LB/LBB/LBD/  
LB-SOL/LFB/LWB

220×95×26 (mm)

6×20 (pcs.)

Neklizajuća ručica od Elastomera.

- Poignée en élastomère antidérapante
- Rutschfester Elastomergriff
- Mango de elastómero antideslizante



## SL-1



LB/LBB/LBD/  
LFB/LWB



220×80×19 (mm)



6×20 (pcs.)

Sa jedinstvenim sistemom za zaključavanje nožića.

- ▮ Avec un système de verrouillage unique.
- ▮ Mit einzigartigem Verschlussystem.
- ▮ Con sistema de bloqueo único.

With unique tractor locking system.

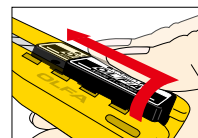

To slide

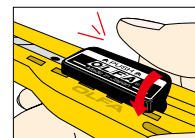

To lock

## EXL



LB/LBB/LBD/  
LB-SOL/LFB/LWB



220×80×27 (mm)



6×20 (pcs.)

Model visokih performansi.

- ▮ Modèle d'un excellent rapport qualité-prix
- ▮ Preis-Leistungs-Modell
- ▮ Modelo de alto rendimiento



## ML



LB/LBB/  
LFB/LWB



220×80×16.5 (mm)



6×20 (pcs.)

Model sa metalnom ručicom.

- ▮ Avec poignée en métal
- ▮ Mit Metallgriff
- ▮ Con mango metálico



## OL



LB/LBB/LBD/  
LB-SOL/LFB/LWB



220×95×23.2 (mm)



6×20 (pcs.)

Sa produženim kanalom za nožić i čeličnim nastavkom.

- ▮ Avec conduit de lame prolongé et corps en acier
- ▮ Mit erweitertem Klingenkanal & Stahl-Falzmesser
- ▮ Con canal para cuchilla amplio y paleta de acero

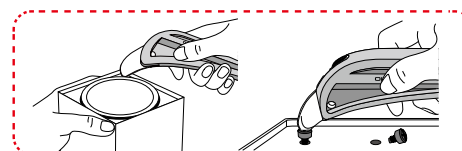
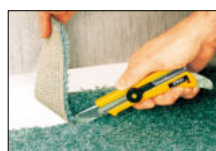

## XL-2



LB/LBB/LBD/  
LB-SOL/LFB/LWB



355×75×26.6 (mm)



6×10 (pcs.)

Za poslove koji zahtevaju dodatnu dužinu.

- ▮ Pour des travaux nécessitant une grande flexibilité
- ▮ Für Arbeiten mit einem größeren Wirkungsbereich
- ▮ Para aquellos trabajos que requieran de mayor alcance

For jobs requiring extra reach



**CL**LB/LBB/LBD/  
LB-SOL/LFB

222×92×25.3 (mm)

6×20 (pcs.)

**Sa graničnikom i dodatkom za skidanje klamerica.**

- Avec entretoise et dégrafeur
- Mit Abstandshalter & Enthefter
- Con espaciador y extractor de grapas

**CMP-2**

LB/LBB/LBD/LFB

240×116×42 (mm)

5×10 (pcs.)

**Kružni skalpel za prečnike od 7cm do 30cm.**

- Cutter circulaire pour diamètre de 7 à 30 cm
- Kreismesser für Durchmesser: 7-30 cm
- Cortador circular para diámetros de 7 a 30 cm

**INSULATION BLADE LWB-3B****Oštrica talasastog oblika lagano seče klizave materijale.**

Sečivo koje čvrsto prijanja na klizave materijale. Čvrsto nazubljeno sečivo prevazilazi i LB nožić priklom sečenja debljih elastičnih materijala kao što su termo izolacije, materijali za obloge plastičnih cevi i kanapi.

Lame dentelée qui serre fermement même les matériaux glissants. La lame dentelée solide surpasse la lame LB pendant la coupe de matériaux élastiques épais tels que les isolants thermiques, couvrant les matériaux pour la tuyauterie et les cordes.

Gezahnte Klinge, die selbst rutschige Materialien fest greift. Die stabile gezahnte Klinge übertrifft die LB-Klinge beim Schneiden dicker elastischer Materialien wie Thermoisolationen, Abdeckmaterialien für Rohre und Seilen.

Cuchilla serrada que fija firmemente hasta los materiales deslizantes. La sólida cuchilla dentada supera el rendimiento de la cuchilla LB cuando se cortan materiales elásticos gruesos, como por ejemplo aislamientos térmicos, cubriendo materiales para tuberías y cuerdas.

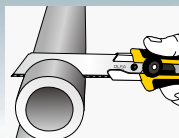

Cevna obloga od Vinila

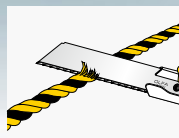

Kanapi

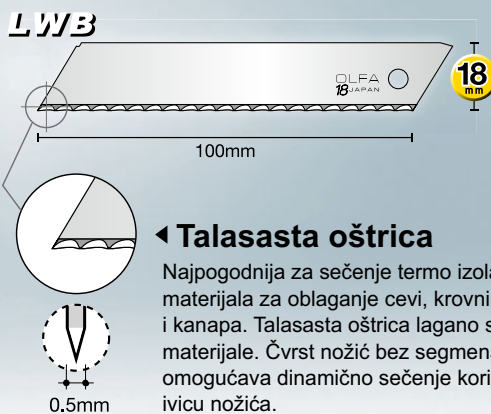

Staklena vuna

**◀ Talasasta oštrica**

Najpogodnija za sečenje termo izolacija, materijala za oblaganje cevi, krovnih materijala i kanapa. Talasasta oštrica lagano seče klizave materijale. Čvrst nožić bez segmenata omogućava dinamično sečenje koristeći celu ivicu nožića.



# Modeli srednje veličine

12.5  
mm

- Modèles médium
- Medium Modelle
- Modelos medianos

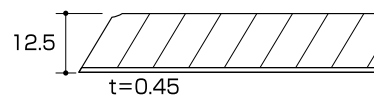

Modeli srednje veličine

## ČVRST a KOMPAKTAN 12.5mm model

Lakši i kompaktniji od modela od 18mm sa dovoljno čvrstim nožićem.

MTB nožić od 12.5mm, debljine 0.45mm je idealan kompromis između nožića od 9mm i 18mm.

- La lame de 0.45mm d'épaisseur 12.5mm MTB est intermédiaire entre la lame de 9mm et la lame de 18mm.
- Die 0.45mm dicke 12.5-mm-MTB-Klinge schließt die Lücke zwischen der 9-mm-Klinge und der 18-mm-Klinge.
- La cuchilla MTB de 0.45mm de grosor y de 12.5mm acorta la distancia entre la cuchilla de 9mm y la de 18mm.



MTB



12.5  
mm  
0.45mm

MTBB



12.5  
mm  
0.45mm



MTB-10B MTBB-10B



### XMT-1



MTBB/MTB

220×80×17.5 (mm)

6×20 (pcs.)

X-dizajn ručica sa automatskim zaključavanjem nožića.  
Ručica od elastomera pojačana staklenim vlaknima otporna na aceton.  
Ugrađeni metalni nastavak za otvaranje konzervi i kanti.

- Une lame plus résistante dans un format compact avec notre poignée X-Design pour une meilleure stabilité.
- Eine robuste Klinge in kompakter Größe mit unserem X-Design-Griff für zusätzliche Stabilität.
- Una cuchilla resistente de un tamaño compacto con nuestro agarre X-Design para mayor estabilidad.



### MT-1



MTB/MTBB

220×80×17 (mm)

6×40 (pcs.)

Najsvestraniji skalpel.

- Le cutter le plus polyvalent
- Das vielseitigste Messer
- El cortador más versátil





## CS-5



MTB/MTBB/SWB-5 228×92×33.8 (mm) 6×10 (pcs.)

Kombinacija testere sa oštrim špicem i nožića od 12,5mm sa segmentima.  
2 u 1 model idealan za električare.

- Une combinaison de scie à œillet et de lame de cutter détachables de 12.5 mm. 2 lames dans 1 poignée pour les électriciens.
- Eine Kombination von Stichsäge und 12.5-mm-Cutter mit Abknick-Klinge. 2 Klingen in 1 Griff für Elektriker.
- Una combinación de sierra tipo cerradura y un cortador con cuchilla desglósable de 12.5 mm. 2 cuchillas en 1 asa para electricistas.



Dvosmerna testera, seče i kada se povlači i kada se gura unapred, ostavljajući za sobom lepo isečenu površinu.

- La lame de scie bidirectionnelle coupe lorsqu'elle est retirée mais aussi lorsqu'elle est poussée, en laissant une surface de coupe propre.
- Das bidirektionale Sägeblatt schneidet beim Ziehen und ebenfalls beim Drücken und hinterlässt eine saubere Schnittoberfläche.
- La cuchilla de sierra bidireccional corta al tirarle ella y también al empujarla, dejando una superficie de corte limpia.

**SWB-5** Testera od 12,5mm za oštrim špicem

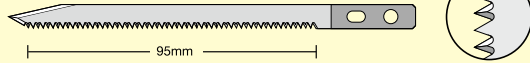

SWB-5/1B



## Profesionalni skalpel za tapete

- Cutter Spécial Papier Peint
- Profi-Tapetenmesser
- Cortador Profesional para Tapizado de Paredes



Za **TAPETE**

### FWP-1



FWB 220×80×16 (mm) 6×40 (pcs.)

Tanji nožić za sečenje zidnih tapeta

- Cutter à lame plus fine pour revêtement mural
- Dünneres Klinge-Wandverkleidungsmesser
- Cortador fino con cuchilla para revestimiento de pared

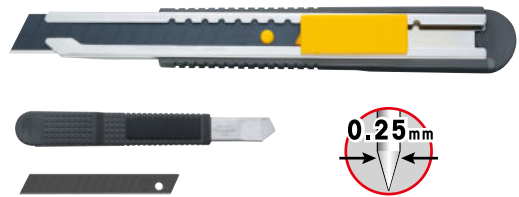

Tanki, ultra oštri nožić od 0,25mm debljine ostavlja prelepo isečenu površinu.

- La lame noire affûtée ultra épaisse de 0.25 mm laisse une belle surface de coupe.
- Die dünne 0.25 mm dicke Ultra Sharp Black-Klinge hinterlässt eine wunderschöne Schnittoberfläche.
- La cuchilla Ultra Sharp Black fina de 0.25 mm de grosor deja una bonita superficie de corte.

**FWB**



1 2 3 4 5 6 7 8 9 10 11 12 13 segmenata

FWB-10



Za **TAPETE**

# Standardni Modeli

9 mm

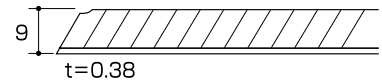

Standardni modeli sa nožićem od 9mm najprikladniji su za potrebe preciznog sečenja kao i za opštu namenu.

## Modèles standards

Avec la lame de 9 mm, les cutters standards sont mieux adaptés pour assurer la précision de coupe ainsi que des utilisations générales.

## Standard Modelle

Mit der 9-mm-Klinge sind Cutter für Standardarbeiten besser geeignet für präzise Schneidearbeiten sowie für allgemeine Aufgaben.

## Modelos estándar

Con una cuchilla de 9 mm, los cortadores para tareas estándar son más adecuados para trabajos de corte precisión así como para fines generales.

Standardni Modeli

### XA-1



ABB/AB/AB-S/AB-SOL



220x80x18 (mm)



6x40 (pcs.)

X-dizajn ručica u prikladnoj i kompaktnoj veličini

- La poignée de conception en X est pratique et compacte
- Griff im X-Design in einer bequemen und kompakten Größe
- Mango de diseño en X en un tamaño cómodo y compacto

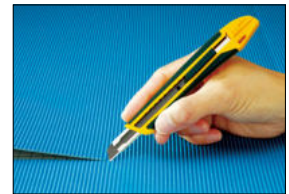

### A-1



AB/ABB/AB-S/SAB/DKB/AB-SOL



220x80x15 (mm)



6x40 (pcs.)

Evolucijski klasik A, sa nastavkom za lomljenje istupljenih segmenata nožića.

- Evolutional Classic A, avec casse-lame/clip
- Evolutionär Klassik A, mit Klingenschnapper/Clip
- Clásico evolutivo A con partidior/clip de cuchilla



### SAC-1



SAB/DKB



220x80x12 (mm)



6x40 (pcs.)

Sa nožićem pod uglom od 30°.

- Avec lame d'angle à 30 degrés
- Mit 30 Grad Winkelklinge
- Con cuchilla en ángulo de 30 grados



### A-5



ABB/AB/AB-S/AB-SOL



220x80x17 (mm)



6x40 (pcs.)

Sa originalnim sistemom jednosmernog zaključavanja.

- Avec système de verrouillage à sens unique
- Mit einseitigem Verriegelungssystem
- Con sistema de bloqueo unidireccional



## SVR-1

STAINLESS  
STEEL  
BLADE

AB-Sx3



AB-S/AB/ABB/AB-SOL



220×80×17.4 (mm)



6×40 (pcs.)

Model od nerđajućeg čelika.

- Tous les modèles en acier inoxydable
- Modell komplett aus Edelstahl
- Todos los modelos son de acero inoxidable



25mm

18mm

12.5mm

9mm

## SVR-2

AUTO  
LOCK

FOR BOTH  
RIGHT AND LEFT  
HANDED USERS

STAINLESS  
STEEL  
BLADE

AB-Sx3



AB-S/AB/ABB/AB-SOL



220×80×12.1 (mm)



6×40 (pcs.)

Model od nerđajućeg čelika.

- Tous les modèles en acier inoxydable
- Modell komplett aus Edelstahl
- Todos los modelos son de acero inoxidable

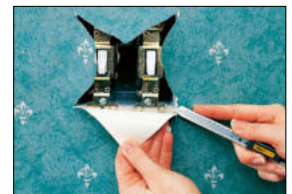

## A-2



AB/ABB/AB-S/AB-SOL



220×80×13.5 (mm)



6×40 (pcs.)

Osnovni model sa gumom protiv proklizavanja.

- Modèle de base avec poignée en caoutchouc
- Grundmodell mit Gummigriff
- Modelo básico con mango de caucho



## DA-1

AUTO  
LOCK

FOR BOTH  
RIGHT AND LEFT  
HANDED USERS



AB/ABB/AB-S



220×80×19 (mm)



6×40 (pcs.)

Sa skladištem za lomljenje/čuvanje istupljenih segmenata nožića.

- Avec casse-lame/boite de lames usagées
- Mit Klingenschnapper/Entsorgungsbehälter
- Con desglosador de cuchillas/ estuche para descartar



## PA-2



ABBx2



ABB/AB/AB-S



220×80×16(mm)



6×40 (pcs.)

Automatsko uzimanje nožića iz skladišta (do 5 nožića).

- | Chargement automatique jusqu'à 5 lames
- | Automatisches Laden mit bis zu 5 Klängen
- | Carga automática de hasta 5 cuchillas

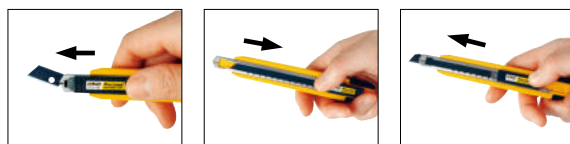

## NA-1



AB/ABB/AB-S/AB-SOL



220×80×20(mm)



6×40 (pcs.)

Neklizajuća ručica od Elastomera.

- | Poignée élastomère antidérapante
- | Rutschfester Elastomergriff
- | Mango de elastómero antideslizante



## 300



AB/ABB/AB-S/AB-SOL



220×80×17.8(mm)



6×20 (pcs.)

Sa sistemom za zaključavanje nožića toččićem.

- | Avec un système de verrouillage par vissage
- | Mit Schraubverschlussystem
- | Con sistema de bloqueo por tornillo



## A-3



AB/ABB/AB-S



220×80×12.2(mm)



6×40 (pcs.)

Skalpel sa dvostrukom funkcijom.

- | Cutter double-sens
- | Zweiseitiges Messer
- | Cuchilla bidireccional



## SPC-1/40

AB/ABB/AB-S/AB-SOL

170×106×103 (mm)

40×20 (pcs.)

Jeftiniji model visokih performansi.

- Modèle d'un excellent rapport qualité-prix
- Preis-Leistungs-Modell
- Modelo de alto rendimiento



25mm

18mm

12.5mm

## ES-1/green

AB/ABB/AB-S/AB-SOL

357×244×10 (mm)

6×40 (pcs.)

Olfa ekološki model. Mogućnost rastavljanja na 5 delova radi reciklaže.

- Permet de démonter en 5 parties pour le recyclage
- Kann zum Recyceln in 5 Teile auseinandergenommen werden
- Permite su desmantelamiento en 5 partes para su reciclaje

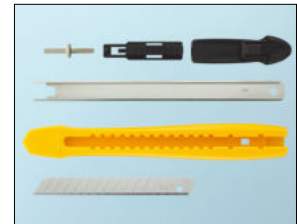

9mm

## S

AB/ABB/AB-S/AB-SOL

220×50×10.6 (mm)

6×80 (pcs.)

## S/20

AB/ABB/AB-S/AB-SOL

357×244×10 (mm)

20×30 (pcs.)

Tanko telo od metala sa dodatkom za lomljenje nožića.

- Corps en métal allégé avec casse-lame/clip
- Schlanker Metallkörper mit Klingenschnapper/Clip
- Cuerpo metálico fino con desglosador de cuchilla/clip



S



S/20

## 180 Black

AB/ABB/AB-S/AB-SOL

220×80×11.9 (mm)

6×40 (pcs.)

## 180-BT/36

AB/ABB/AB-S/AB-SOL

248×145×163 (mm)

36×10 (pcs.)

Telo od metala sa dodatkom za lomljenje nožića.

- Poignée métallique avec casse-lame/clip
- Metallgriff mit Klingenschnapper/Clip
- Mango metálico con desglosador de cuchillas/clip



180 Black



180-BT/36



# Kutije za odlaganje nožića

OLFA kutije za odlaganje pomažu korisnicima da otkinu segment nožića i odlože ga unutra do bacanja.



## Boite de lames usagées.

Garder le bord de la lame constamment affûté entraîne la sécurité. Les boîtes de lames usagées OLFA aident les utilisateurs à casser une lame et à ranger en toute sécurité des morceaux de lame usées jusqu'au rebut de ces derniers.

## Entsorgungsbehälter

Das ständige Scharfhalten der Klingenschnede führt zu mehr Sicherheit. OLFA Klengen-Entsorgungsbehälter helfen Verwendern, eine Klinge abzubrechen und gebrauchte Klingensegmente sicher aufzubewahren, bis sie entsorgt werden.

## Estuche para descarte.

Mantener el filo afilado todo el tiempo para aumentar la seguridad. Los estuches para el desecho de cuchillas OLFA ayuda a los usuarios a desglasar una cuchilla y almacenar los segmentos usados de la cuchilla de forma segura hasta que se deshaga de ellos.

Kutije za odlaganje nožića ■ Makaze

## DC-2



159×105×54 (mm)

6×20 (pcs.)

## DC-3



269×70×67 (mm)



10×20 (pcs.)

## DC-4



148×72×29 (mm)

6×20 (pcs.)

### Zbog sigurnosti, očuvanja okoline. Za dobijanje nove oštre ivice na bezbedan način.

Par mesure de sécurité, pour des raisons environnementales et de convenance. Pour obtenir confortablement et en toute sécurité des points de coupe nets.

Für Sicherheit, Umwelt & Komfort. Für das bequeme & sichere Erlangen eines frischen Schneidepunktes.

Por motivos de seguridad, medioambiente y conveniencia. Para obtener un punto de corte preciso, confortable y seguro.



## DC-6

**PAT.**



200×100×83 (mm)



5×10 (pcs.)

Stona kutija za odlaganje istupljenih segmenata.

- Solution complète de bureau pour rangement de lames.
- Komplettes arbeitsoberflächenklengenentsorgungssystem.
- Sistema completo de desecho de cuchillas para escritorios.



## DC-5



269×70×67 (mm)



6×20 (pcs.)

Kutija - Futrola za odlaganje istupljenih segmenata.

- Etui pour lames usagées
- Klengenentsorgungshalterung
- Portador de hojas desechables



※DC-6 nije kompatibilan: Sa svim modelima nožića od 25mm.  
Modelima od 18mm: CL, OL, PL-1, SL-1, CMP-2, LL, ML.  
Modelima od 9mm: PA-2, SPC-1, ES-1/green.

※Le DC-6 n'est PAS compatible avec : Tous les modèles supplémentaires pour les gros travaux de 25 mm, modèles pour gros travaux de 18 mm : CL, OL, PL-1, SL-1, CMP-2, ML et les modèles standard de 9 mm : PA-2, SPC-1, ES-1/vert.

※Das DC-6 ist NICHT kompatibel mit: Allen 25-mm-Modellen für extra schwere Arbeiten, 18-mm-Modellen für schwere Arbeiten: CL, OL, PL-1, SL-1, CMP-2, ML und 9 mm Modellen für Standardarbeiten: PA-2, SPC-1, ES-1/grün.

※El DC-6 NO es compatible con: Todos los modelos de uso industrial extra de 25 mm, modelos de uso industrial de 18 mm: CL, OL, PL-1, SL-1, CMP-2, ML y modelos de uso estándar de 9 mm: PA-2, SPC-1, ES-1/verde.

※DC-5 nije kompatibilan: Sa svim modelima nožića od 25mm.  
Modelima od 18mm: CL, PL-1, SL-1, CMP-2.  
Modelima od 9mm: PA-2, SPC-1, ES-1/green.

※Le DC-5 n'est PAS compatible avec : Tous les modèles supplémentaires pour gros travaux de 25 mm, modèles de 18 mm pour gros travaux : CL, PL-1, SL-1, CMP-2 et les modèles standard de 9 mm : PA-2, SPC-1, ES-1/vert.

※Das DC-5 ist NICHT kompatibel mit: Allen 25-mm-Modellen für extra schwere Arbeiten, 18-mm-Modellen für schwere Arbeiten: CL, PL-1, SL-1, CMP-2 und 9-mm-Modellen für Standardarbeiten: PA-2, SPC-1, ES-1/grün.

※El DC-5 NO es compatible con: Todos los modelos de uso industrial extra de 25 mm, modelos de uso industrial de 18 mm: CL, PL-1, SL-1, CMP-2 y los modelos de uso estándar de 9 mm: PA-2, SPC-1, ES-1/verde.



# Makaze

OLFA makaze sa ravnim ili nazubljenim oštricama za raznovrsne poslove sečenja.

## Ciseaux

Ciseaux OLFA avec lame plate, avec lame dentée pour le travail polyvalent.

## Scheren

OLFA Scheren mit gerader Schneide, mit gezahnter Schneide für vielseitige Arbeiten.

## Tijeras

Las tijeras OLFA con filo recto, con filo en sierra para trabajo versátil.



### SCS-1

STAINLESS  
STEEL  
BLADE



220×95×9.7 (mm)



6×20 (pcs.)

Model od nerđajućeg čelika sa nazubljenim oštricama, manje.

- Ciseaux dentés résistants, petit modèle
- Grob gezackte Scheren, Klein
- Tijeras dentadas resistentes, Pequeñas



(Uvećan prikaz oštrice)



### SCS-2

STAINLESS  
STEEL  
BLADE



220×105×13.5 (mm)



6×20 (pcs.)

Model od nerđajućeg čelika sa nazubljenim oštricama, veće.

- Ciseaux dentés résistants, grand modèle
- Grob gezackte Scheren, Groß
- Tijeras dentadas resistentes, Grandes

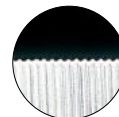

(Uvećan prikaz oštrice)

### SCS-3

STAINLESS  
STEEL  
BLADE



220×95×11 (mm)



6×20 (pcs.)

Model od nerđajućeg čelika sa nazubljenim oštricama, visokih performansi.

- Modèle d'un excellent rapport qualité-prix
- Preis-Leistungs-Modell
- Modelo de alto rendimiento

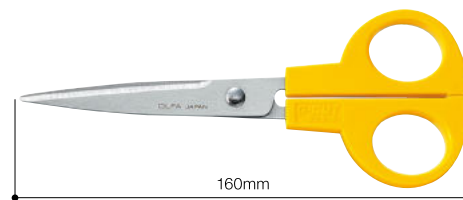

(Uvećan prikaz oštrice)



### SCS-4

STAINLESS  
STEEL  
BLADE



220×95×10 (mm)



6×20 (pcs.)

Model od nerđajućeg za preciznije poslove.

- Pour un travail plus précis
- Für genaueres Arbeiten
- Para un trabajo más preciso



(Uvećan prikaz oštrice)

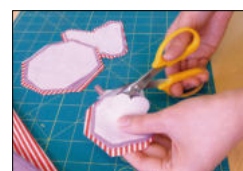

# Sigurnosni modeli

Svaki OLFA Sigurnosni skalpel daje doprinos sigurnim radnim uslovima.

## Modèles de sécurité

Chaque couteau de sécurité OLFA contribue à des conditions de travail en toute sécurité.

## Sicherheits-Modelle

Liefert jedes OLFA Sicherheitsmesser einen Beitrag zu sicheren Arbeitsbedingungen.

## Modelos de seguridad

Cada cuchillo de seguridad OLFA contribuye a unas condiciones de trabajo seguras.



Sigurnosni modeli

### SK-16



Ovaj sigurnosni skalpel sa nožićem koji se menja je dizajniran tako da budete sigurni i zaštićeni prilikom rukovanja.

Idealan za otpakivanje, sečenje kartona, tepiha, čak i tvrdih i debljih podnih materijala. Ručica je ojačana staklenim vlaknima čime je povećana njegova trajnost, i dovoljno je čvrst i za profesionalnu upotrebu.

Zamena nožića je jednostavna a na kraju je opremljen metalnim nastavkom za sečenje traka.



Cette lame de sécurité remplaçable est conçue de telle sorte que vous pouvez opérer en toute sécurité pendant la manipulation. Idéal pour le déballage, la découpe de carton, de moquette et même des revêtements de sol robustes. La poignée est renforcée avec de la fibre de verre pour la durabilité et est suffisamment résistante pour une utilisation professionnelle. Le changement de la lame est simple, et une découpeuse de bande métallique est fournie pour plus de commodité.

Der austauschbare Sicherheitscutter wurde speziell für eine sichere Handhabung konstruiert. Ideal zum Auspacken, Schneiden von Karton, Teppich und sogar schweren Bodenbelägen. Der Griff ist für höhere Haltbarkeit mit Glasfaser verstärkt und robust genug für professionelle Anwender. Der Austausch der Klinge ist einfach und der Cutter verfügt zudem über einen praktischen Klebebandschneider aus Metall.

Este cortador de seguridad reemplazable está diseñado para que se mantenga seguro durante la manipulación. Ideal para desembalar, cortar cartón, moqueta y materiales pesados para suelos. El mango está reforzado con fibra de vidrio para mayor durabilidad y es lo suficientemente resistente como para un uso profesional. El cambio de la cuchilla es simple y también viene con un cortador de cinta metálico para mayor comodidad.



### SK-15/10

### SK-15/10/BLU

### SK-15/10/WHT

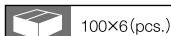
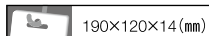

Sigurnosni skalpel sa sakrivenim nožićem i nastavkom sa sečenje traka.

Cutter avec massicot intégré pour tous vos besoins de déballage.

Cutter mit einziehbarer Klinge und eingebautem Klebebandschneider für alle Auspackbedürfnisse.

Cortador de cuchilla oculta con cortador de cinta integrado para todas las necesidades de desembalaje.



SK-15/10



SK-15/10/BLU



SK-15/10/WHT



### SK-15/DSB

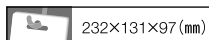

## SK-4



SKB-2/SKB-2S/SKB-2S-R/  
RSKB-2/HOB-2

220×80×25.1 (mm)

6×20 (pcs.)



Najprodavaniji sigurnosni skalpel.

- Le cutter de sécurité le plus vendu
- Das meistverkaufte Sicherheitsmesser
- El cortador de seguridad más vendido

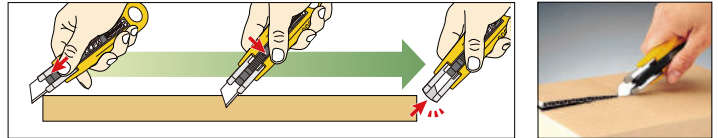

25mm

18mm

12.5mm

9mm

## SK-4/24



SKB-2/SKB-2S/SKB-2S-R/  
RSKB-2/HOB-2

257×170×139 (mm)

24×6 (pcs.)



Pakovanje za uštedu od 24 komada.

- Emballage en vrac pour des économies de coûts
- Kostengünstige Großpackung
- Paquete a granel económico

## SK-4/green



SKB-2/SKB-2S/SKB-2S-R/  
RSKB-2/HOB-2

220×80×26 (mm)

6×20 (pcs.)



Ekološka verzija popularnog sigurnosnog skalpela.

- Version écologique du cutter de sécurité populaire
- Öko-Version des beliebten Sicherheitsmessers
- Versión ecológica de la popular cuchilla de seguridad

## SK-4/HOK



HOB-2/SKB-2/SKB-2S/  
SKB-2S-R/RSKB-2/

220×80×23 (mm)

6×20 (pcs.)



Najprodavaniji sigurnosni skalpel sa HOB-2 nožićem sa kukicom.

- Longue lame de sécurité SK-4, préchargée avec une lame à crochet HOB-2
- Der beliebte Sicherheitscutter SK-4 kommt mit einer HOB-2-Hakenklinge
- Una cuchilla resistente de un tamaño compacto con nuestro agarre X-Design para mayor estabilidad



## SK-5



SKB-2/SKB-2S/SKB-2S-R/  
RSKB-2/HOB-2

220×80×22.4 (mm)

6×20 (pcs.)



Neklizajuća ručica od Elastomera.

- Poignée en élastomère antidérapante
- Rutschfester Elastomergriff
- Mango de elastómero antideslizante

### SK-6



RSKB-2 220×95×20 (mm) 6×12 (pcs.)

Automatski zaštitni sistem.

- | Carter de protection automatique
- | Automatische Schutz Einrichtung
- | Cubierta de protección automática

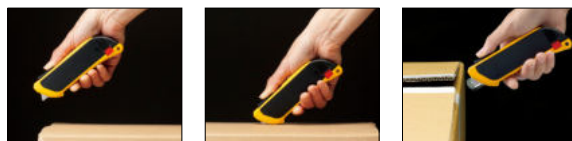

### SK-7



SKB-7 220×80×17.6 (mm) 6×20 (pcs.)

Kompaktni sigurnosni skalpel.

- | Cutter de sécurité compact
- | Kompaktes Sicherheitsmesser
- | Cortador de seguridad compacto



### SK-7/green



SKB-7 220×80×16 (mm) 6×20 (pcs.)

Kompaktni sigurnosni skalpel. Ekološka verzija.

- | Cutter de sécurité compact
- | Kompaktes Sicherheitsmesser
- | Cortador de seguridad compacto



### SK-7/24



SKB-7 198×141×76 (mm) 24×12 (pcs.)

Pakovanje za uštedu od 24 komada.

- | Emballage en vrac pour des économies de coûts
- | Kostengünstige Großpackung
- | Paquete a granel económico



### SK-8



SKB-8 220×95×24.1 (mm) 6×20 (pcs.)

Sistem automatskog uvlačenja nožića.

- | Système auto-rétractable automatique
- | Automatisches selbststeinziehendes System
- | Sistema auto-retractil automático



### SK-8/24



SKB-8 257×184×128 (mm) 24×6 (pcs.)

Pakovanje za uštedu od 24 komada.

- | Emballage en vrac pour des économies de coûts
- | Kostengünstige Großpackung
- | Paquete a granel económico





## SK-9



SKB-2/SKB-2S/SKB-2S-R/  
RSKB-2/HOB-2

222×92×21 (mm)

6×20 (pcs.)

Sa metalnim nastavkom.

- | Avec découpeuse à ruban métallique
- | Mit Metall-Bandlängsschneider
- | Con cortador de cinta de metal



## SK-9/32



SKB-2/SKB-2S/SKB-2S-R/  
RSKB-2/HOB-2

258×184×130 (mm)

32×4 (pcs.)

Pakovanje za uštedu od 32 komada.

- | Emballage en vrac pour des économies de coûts
- | Kostengünstige Großpackung
- | Paquete a granel económico



## SK-10



SKB-10

220×95×13 (mm)

6×20 (pcs.)

Skalpel za trake i streč foliju.

- | Cutter extensible pour emballage
- | Streckverpackungs messer
- | Cutter para flejes y films

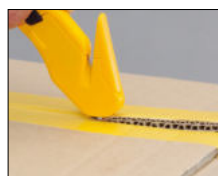

## SK-10/24



SKB-10

234×212×86 (mm)

24×8 (pcs.)

Pakovanje za uštedu od 24 komada.

- | Emballage en vrac pour des économies de coûts
- | Kostengünstige Großpackung
- | Paquete a granel económico





## SK-12



Skalpel od nerđajućeg čelika sa automatskim uvlačenjem nožića.  
 Odobren od strane NSF.

※SK-12 nije namenjen za sečenje hrane.

- Cutter "sécurité", lame inox auto rétractable.  
 Lavabilité certifiée NSF.  
 ※Le SK-12 n'est PAS conçu pour découper des aliments.
- Sicherheitsmesser aus Edelstahl.  
 NSF-zertifizierte Waschbarkeit.  
 ※Das SK-12 ist NICHT zum Schneiden von Lebensmitteln gedacht.
- Cutter de seguridad auto retráctil 100% inoxidable.  
 Lavabilidad con certificación NSF.  
 ※SK-12 NO ha sido diseñado para cortar alimentos.



## SK-12/24



Pakovanje za uštedu od 24 komada.

- Emballage en vrac pour des économies de coûts
- Kostengünstige Großpackung
- Paquete a granel económico



## SK-12 Instrukcije za čišćenje

Instructions de nettoyage | Reinigungsanweisung | Instrucciones de limpieza

### 1 Pranje

- Lavage
- Waschen
- Lavado

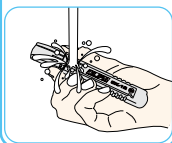

### 2 Čišćenje hemikalijama

U razblaženom rastvoru natrijum hipohlorita  
 100ppm / maksimum 5 min.

■ Nettoyage chimique  
 Dans une solution diluée d'hypochlorite de sodium 100 ppm/ 5 minutes maximum.

■ Chemische Reinigung  
 In einer verdünnten Lösung von Natriumhypochlorit 100 ppm/ Maximal 5 Min.

■ Limpieza química  
 En solución diluida de hipoclorito sódico de 100 ppm/ Máximo 5 min.

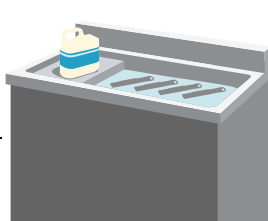

### 3 Dobro isprati vodom

- Bien rincer à l'eau courante.
- Gut unter fließendem Wasser abspülen.
- Enjuague bien con agua corriente.

### 4 Dobro osušiti

- Bien sécher. ■ Gut trocknen.
- Seque completamente.

## Laka zamena nožića

Échange de lame facile et sans outil | Einfacher Klingenaustausch ohne Werkzeug  
 Intercambio fácil de cuchilla sin necesidad de herramientas

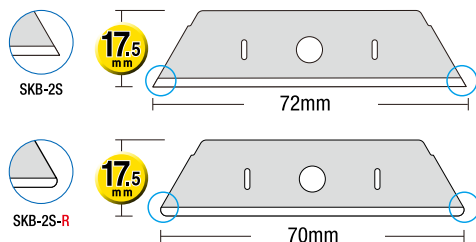

### Vadenje nožića | Pour le déchargement | Zum Entladen | Para la descarga

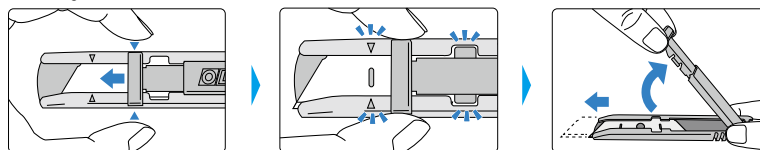

### Stavljanje nožića | Pour le chargement | Zum Laden | Para la carga

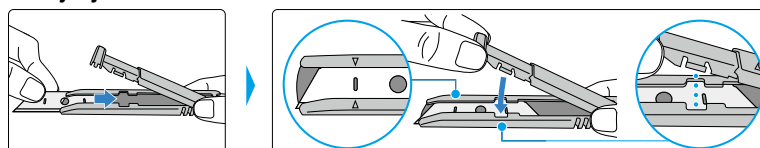

### 2 strane za sečenje

- 2 Bords de coupe par lame
- 2 Schneidekanten pro Klinge
- 2 filos de corte por cuchilla

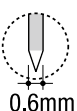

# Strugači

OLFA strugači od zgodnih malih do ozbiljno velikih.  
Prilagođeni za uklanjanje nečistoća i struganje raznih površina.

## Grattoirs

De type à portée de main à type robuste, les racleurs OLFA s'adaptent au retrait, au raclement et aux travaux de coupe.

## Schabmesser

Vom praktischen Typ bis zum Typ für schwere Arbeiten, OLFA Schaber decken Arbeiten wie Entfernen, Schaben und Schneiden ab.

## Raspadores

Desde tipo práctico a tipo de uso industrial, los raspadores OLFA acomodan las tareas de extracción, raspado y corte.

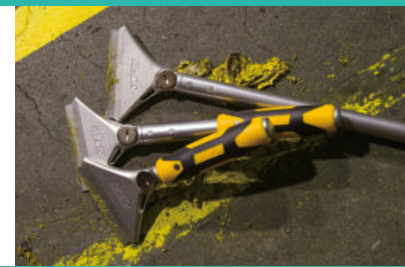

## Profesionalni strugači serije XSR sa jakim i čvrstom ručicom i jakim heavy-duty nožićem 0.8mm debljine.

- La série de racleur XSR professionnel offre une extrémité de poignée de martelable et une lame épaisse robuste 0,8 mm comme équipement standard.
- Die professionelle XSR Schaberserie hat ein hämmerebares Griffende und eine 0,8 mm dicke Klinge für schwere Arbeiten als Standardausrüstung.
- La serie de raspadores profesionales XSR ofrecen una toma en el extremo que se puede utilizar con un martillo y una cuchilla de uso industrial de 0,8 mm de grosor como equipo estándar.

### XSR-200



BS08/BS/BSF/LB



270×145×25 (mm)



5×6 (pcs.)

Strugač sa 200mm dugačkom X-dizajn ručicom.

- Racleur avec poignée de conception longue de 200 mm
- Schaber mit 200 mm langem X-Design Griff
- Rascador con un mango con diseño dexde una longitud de 200 mm



### XSR-300



BS08/BS/BSF/LB



350×145×25 (mm)



5×6 (pcs.)

Strugač sa 300mm dugačkom X-dizajn ručicom.

- Racleur avec poignée de conception longue de 300 mm
- Schaber mit 300 mm langem X-Design Griff
- Rascador con un mango con diseño dexde una longitud de 300 mm



### XSR-600



BS08/BS/BSF/LB



655×145×25 (mm)



5×6 (pcs.)

Strugač sa 600mm dugačkom X-dizajn ručicom.

- Racleur avec poignée de conception longue de 600 mm
- Schaber mit 600 mm langem X-Design Griff
- Rascador con un mango con diseño dexde una longitud de 600 mm

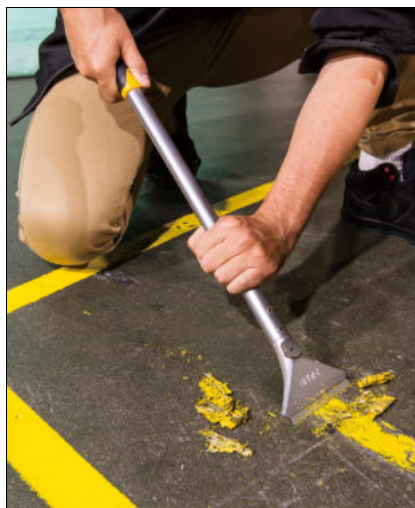
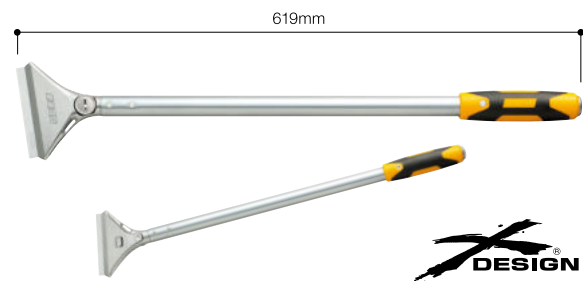

**Pogodni za staklene površine. Odlična otpornost na rastvarače, na rđu takođe. Svi metalni delovi izrađeni su od nerđajućeg čelika. Rukohvat i nožić iste dužine. Pogodan za uglove i skućene prostore.**

Convient aux surfaces en verre. Excellente résistance aux solvants. Résiste efficacement à la rouille, aussi. Peut être utilisé dans les travaux de plomberie. Toutes les pièces métalliques sont en acier inoxydable. Lame et poignée de la même largeur. Peut être utilisé pour travailler dans les coins et dans des ouvertures restreintes.

Geeignet für Glasflächen. Ausgezeichnete Lösungsmittelbeständigkeit. Auch stark gegen Rost. Kann für Klempnerarbeiten verwendet werden. Alle Metallteile sind aus Edelstahl gefertigt. Die Klinge und der Griff sind gleich breit. Kann für Arbeiten in Ecken und in engen Öffnungen verwendet werden.

Apto para superficies de vidrio. Excelente resistencia a los disolventes. Igualmente, resistente contra el óxido. Se puede utilizar en trabajos de fontanería. Todas las piezas metálicas están hechas de acero inoxidable. Cuchilla y mango de la misma anchura. Se puede utilizar para trabajar en esquinas y aberturas estrechas.

### GSR-1/3B



FOR BOTH  
RIGHT AND LEFT  
HANDED USERS



STAINLESS  
STEEL  
BLADE

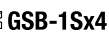

ACETONE  
RESISTANT

GSB-1Sx4



GSB-1S



220×130×16.8 (mm)



6×10 (pcs.)

Širina nožića: 120mm

Largeur de la lame : 120 mm

Klingenbreite: 120 mm

Anchura de la cuchilla: 120 mm



### GSR-2



FOR BOTH  
RIGHT AND LEFT  
HANDED USERS



STAINLESS  
STEEL  
BLADE



ACETONE  
RESISTANT

GSB-2Sx6



GSB-2S/GSB-1S



220×95×17.8 (mm)



6×20 (pcs.)

Širina nožića: 40mm

Rezervni nožići se mogu čuvati u poklopcu nožića.

Poklopac nožića se tokom upotrebe može postaviti u rupu na ručici.

Largeur de la lame : 40 mm  
Les lames de rechange peuvent être rangées dans le couvercle de la lame.  
La boîte de lame de rechange se monte sur la poignée pendant l'utilisation.

Klingenbreite: 40 mm  
Ersatzklingen können in der Klingendeckung aufbewahrt werden.  
Das Ersatzklingengehäuse wird während des Gebrauchs am Griff befestigt.

Anchura de la cuchilla: 40 mm  
Las cuchillas de repuesto pueden guardarse en la cubierta de la cuchilla.  
El estuche de cuchillas de repuesto se monta en el mango durante el uso.



## BTC-1



ONE-SIDED SHARPENING



BTB-1



220×95×20.3 (mm)



6×20 (pcs.)

Svestrani skalpel za sečenje kože i drugih materijala, strugač za staklo.

- Grattoir polyvalent permettant de couper facilement le cuir et les feuilles de résine
- Vielseitige Abziehklinge, die sehr gut zum Schneiden von Leder und Kunststoffplatten geeignet ist
- Cuchilla versátil que funciona bien para cortar cuero y láminas de resina



### Strugač sa jedinstvenim nožićem sa oštricom na sve 4 strane.

- Grattoir maniable avec lame en arc multi-tranchants.
- Handliches Schabmesser mit mehrschneidiger Bogenklinge.
- Raspador práctico con cuchilla de arco de varios filos.

## T-45



ONE-SIDED SHARPENING



TB-45



220×95×26 (mm)



3×40 (pcs.)

Širina nožića: 45mm

- Largeur de la lame : 45 mm
- Klingenbreite: 45 mm
- Anchura de la cuchilla: 45 mm

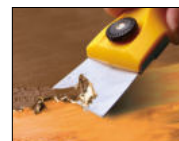

### Kompaktni strugači za čišćenje podova i stakala.

- Grattoirs compacts pour le nettoyage des sols et des fours à porte en verre.
- Kompakt-Schabmesser zum Reinigen des Bodens & der Ofenglasdecke.
- Raspadores compactos para la limpieza de suelos y cubiertas de cristal de hornos.

## SCR-S



STAINLESS STEEL BLADE

ONE-SIDED SHARPENING



220×80×14 (mm)



6×20 (pcs.)

Širina nožića: 25mm

- Largeur de la lame : 25 mm
- Klingenbreite: 25 mm
- Anchura de la cuchilla: 25 mm



## SCR-M



STAINLESS STEEL BLADE

ONE-SIDED SHARPENING



220×80×14.8 (mm)



6×20 (pcs.)

Širina nožića: 43mm

- Largeur de la lame : 43 mm
- Klingenbreite: 43 mm
- Anchura de la cuchilla: 43 mm



## SCR-L



STAINLESS STEEL BLADE

ONE-SIDED SHARPENING



220×80×14 (mm)



6×20 (pcs.)

Širina nožića: 60mm

- Largeur de la lame : 60 mm
- Klingenbreite: 60 mm
- Anchura de la cuchilla: 60 mm





# Rotacioni skalpeli

OLFA je 1979 godine izumom Rotacionog Skalpela napravila revoluciju u načinu sečenja tkanine, i donela mnoge olakšice i pogodnosti koje nisu mogle ni da se zamisle u to vreme.

## Cutters rotatifs

L'invention du cutter rotatif d'OLFA en 1979 a totalement modifié le monde des techniques de piquage et livré une commodité extraordinaire que personne ne pouvait imaginer à l'époque.

## Rundmesser

OLFAs Erfindung des Rotationscutters 1979 veränderte die Welt der Quiltingtechniken komplett und bietet außergewöhnlichen Komfort, den sich bis dahin niemand vorstellen konnte.

## Cortadores rotativos

La invención del cortador rotativo de OLFA en 1979 cambió totalmente el mundo de las técnicas de acolchado y proporcionó una conveniencia extraordinaria que nadie podía imaginarse entonces.



Rotacioni skalpeli

## Modeli koje vole mnoge zanatlije.

Jednostavne funkcije pomažu korisnicima u njihovoj kreativnosti dugi niz godina.

Apprécié par de nombreux artisans et amateurs de bricolage dans le monde depuis sa mise sur le marché en 1979. Ses fonctions de base simples aident à la créativité de son utilisateur depuis de longues années.

Von vielen Quilt-Herstellern und Handwerksbegeisterten weltweit seit der Einführung 1979 geliebt. Einfache und grundlegende Funktionen unterstützen über viele Jahre die Kreativität des Benutzers.

Adorado por muchos entusiastas de la artesanía y costura de todo el mundo desde su lanzamiento en 1979. Funciones simples y básicas para ayudar durante muchos años a la creatividad del usuario.

## RTY-2/G



RB45/RB45H



219x114x20 (mm)



6x20 (pcs.)

Osnovni model za široku primenu.

- Modèle de base pour de multiples applications
- Grundmodell für umfangreiche Anwendungen
- Modelo básico para numerosas aplicaciones



## OLFA set je perfektan poklon za sve koji se bave krojenjem, izradom pačvorka...

Le kit de matelassage premium est le cadeau idéal, parfait pour un débutant en matelassage, une personne qui va à des cours de matelassage ainsi que pour un formateur ou un enseignant.

Das Premium-Quilt-Herstellungsset eignet sich hervorragend als besonderes Geschenk für einen Anfänger im Quilten, Quilt-Kursteilnehmer oder für Quilt-Lehrer.

El kit premium para costura es el regalo ideal para los costureros principiantes, los participantes de clases de costura, educadores o profesores.

## RTY-ST/QR

## RTY-ST/QR-METRIC



RB45/RB45H



490x315x25 (mm)



5x5 (pcs.)

Set sadrži RTY-2/G rotacioni skalpel, RM-IC-C podlogu za sečenje (470 x 320 x 1.6mm) i QR-6S ili QR-15 x 16 lenjir.

Le kit de matelassage premium contient le cutter rotatif RTY-2/G, un tapis rotatif (470 x 320 x 1,6 mm) et une règle de matelassage QR-6S ou QR-15x16 exclusive pour le kit.

Das Premium-Quilt-Herstellungsset enthält den RTY-2/G-Rotationscutter, die RM-IC-C-Rotationsmatte (470 x 320 x 1,6 mm) und exklusiv für das Set das QR-6S- oder QR-15x16-Quilt-Lineal.

El kit premium para costura contiene el cortador rotativo RTY-2/G, la estera giratoria RM-IC-C (470 x 320 x 1,6 mm) y el kit exclusivo QR-6S o la regla de costura QR-15x16.

Inči

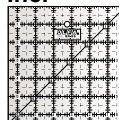

ili

cm

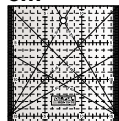

## RTY-ST/QR-RC

## RTY-ST/QR/METRIC-RC



RB45/RB45H



490x315x25 (mm)



5x5 (pcs.)

Ekološka verzija sa podlogom za sečenje bez DEHP-a za Evropsko tržište.

- Tapis de coupe sans DEHP, respectueux de l'environnement, conçu pour le marché européen
- Für den europäischen Markt konzipierte umweltfreundliche und DEHP-freie Schneidmatte
- Soporte para cortar libre de DEHP respetuoso con el medio ambiente diseñado para el mercado europeo

\* DEHP: Deo sintetičke hemikalije koja se koristi da bi plastika dobila veću fleksibilnost.

Inči

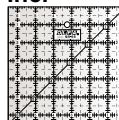

ili

cm

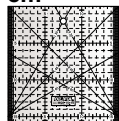



## RTY-3/G



RB60/RB60H



250×125×22.9 (mm)



6×20 (pcs.)

Veći model sa moćnim nožićem.

- Modèle le plus grand avec lame puissante
- Größtes Modell mit kraftvoller Klinge
- El mayor modelo con una poderosa cuchilla



## RTY-4



STAINLESS  
STEEL  
BLADE

RB18/PRB18



220×80×14 (mm)



6×20 (pcs.)

Za detaljne radove

- Pour travaux détaillés
- Für detaillierte Arbeiten
- Para trabajos detallados



### Sigurnosni sistem zaključavanja. Dizajniran da smanji umor u rukama i potencijalno povređivanje.

La série DX dispose d'un système de verrouillage de sécurité. Conçu pour réduire la fatigue manuelle et les blessures potentielles sur le lieu de travail.

Die DX-Reihe bietet ein Sicherheitsverriegelungssystem. Entwickelt, um die Handermüdung und potentielle Verletzungen am Arbeitsplatz zu verringern.

La serie DX posee un sistema de bloqueo de seguridad. Diseñado para reducir el cansancio de la mano y posibles lesiones durante el trabajo.

## RTY-2/DX



PAT.

RB45/RB45H/  
PIB45/WAB45



220×113×28 (mm)



6×12 (pcs.)

Nožić od 45mm. Može koristiti i dekorativne rezervne nožiče.

- Avec une lame de 45 mm, peut s'adapter aux lames décoratives
- Mit 45 mm Klinge, kann dekorative Klingen unterbringen
- Con cuchilla de 45 mm, puede acomodar cuchillas decorativas

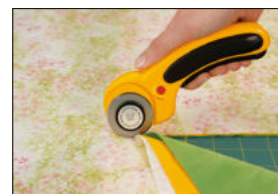

## RTY-3/DX



PAT.

RB60/RB60H



250×125×29 (mm)



6×10 (pcs.)

Veći model sa nožićem od 60mm.

- Grand modèle avec lame de 60 mm
- Großes Modell mit 60 mm Klinge
- Modelo superior con cuchilla de 60 mm

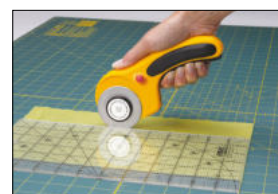

### Model visokih performansi. Brza zamena nožića.

Cutter rotatif haute performance doté d'un changement rapide de lame.

Hochleistungs-Rotationsschneider mit schnellem Klinsenwechsel.

Cúter giratorio de gran rendimiento con cambio de cuchilla rápido.

#### RTY-1/C



RB28/PRB28

220×80×16.2(mm)

6×20(pcs.)

Manji model sa nožićem od 28mm.

Petit modèle avec lame de 28 mm

Kleines Modell mit 28 mm Klinge

Modelo reducido con cuchilla de 28 mm

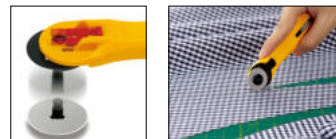

#### RTY-2/C



PAT.

RB45/RB45H

219×114×21(mm)

6×12(pcs.)

#### RTY-2C/YEL



PAT.

RB45/RB45H

219×114×21(mm)

6×12(pcs.)

#### RTY-2C/PIK



PAT.

RB45/RB45H

219×114×21(mm)

6×12(pcs.)

Osnovni model za široku primenu.

Modèle de base pour de multiples applications

Grundmodell für umfangreiche Anwendungen

Modelo básico para numerosas aplicaciones



RTY-2/C



RTY-2C/YEL



RTY-2C/PIK



## Kombinacija sistema za brzu zamenu nožića, podeljenog poklopca (zaštite) nožića i ergonomске Comfort Grip ručice.

Association d'un changement rapide de lame, d'un couvercle de lame fendu et d'une poignée ergonomique confortable.

Eine Kombination aus schnellem Klingenswechsel, geteilter Klingendeckung und ergonomischem Komfortgriff.

Combinación de cambio de cuchilla rápido, cubierta de cuchilla dividida y empuñadura cómoda y ergonómica.

### RTY-2/NS



RB45/RB45H

219×114×23 (mm)

6×12 (pcs.)

Pogodan za višestruku upotrebu.

- Parfait pour des utilisations variées
- Für verschiedene Verwendungen perfekt geeignet
- Perfecto para diferentes usos

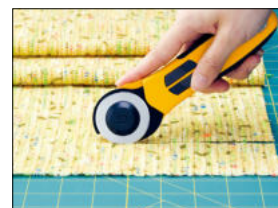

### CMP-3

STAINLESS STEEL BLADE

PAT.

RB18

220×115×29 (mm)

6×20 (pcs.)

Za sečenje tkanine i materijala u prečniku od 4 do 22cm.

- Coupe des cercles de tissu d'un diamètre de 4 à 22 cm
- Schneidet Stoff mit einem Kreisdurchmesser von 4-22 cm
- Corta tela con un diámetro de círculo de 4-22 cm

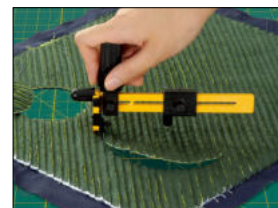

### CHN-1



PAT.

CHB

220×115×25.7 (mm)

6×10 (pcs.)

Za sečenje tkanine i materijala sa 4 kanala (vođice).

- Cutter chenille avec 4 guides de conduit
- Chenille-Messer mit 4 Führungskanälen
- Cortador de felpa con 4 guías de canal

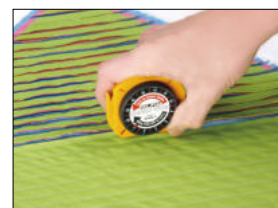

## PRC-2



STAINLESS  
STEEL  
BLADE



PRB18/RB18



220×80×15 (mm)



6×20 (pcs.)

Skalpel za perforaciju sa nožićem od nerđajućeg čelika od 18mm.

- Cutter de perforation avec lame en acier inoxydable de 18 mm pour effectuer des lignes perforées.
- Perforationschneider mit einer 18-mm-Edelstahl Klinge zur Erstellung perforierter Linien.
- Cúter de perforación con cuchilla de acero inoxidable de 18 mm para realizar líneas perforadas.



## PRC-3/C



PRB28/RB28



220×80×16 (mm)



6×20 (pcs.)

Skalpel za perforaciju dubokim urezima na nožiću od 28mm. Visokih performansi sa sistemom za brzu zamenu nožića.

- Doté d'une lame en alliage d'acier avec des dents de 28 mm, le PRC-3/C sera très apprécié par les utilisateurs fréquents de découpe perforée. Changement de lame rapide en un simple clic.
- Das PRC-3/C verfügt über eine Werkzeug Klinge aus einer Stahlliegierung mit einem 28 mm tiefen Wellenschliff und wird von Anwendern für häufige Perforationsschneidarbeiten bevorzugt. Schneller Klängenwechsel mit nur einem Klick.
- Con una hoja de aleación de acero con filo de dientes de sierra profundos y 28 mm, el PRC-3/C será la mejor elección para usuarios habituales del corte perforado. Cambio rápido de la cuchilla con un solo clic.

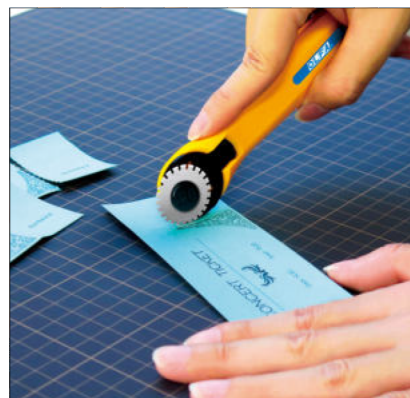





## Izdržljiv nožić - Premium Rotary Blade -

### Dugotrajni



### RB45H



### RB60H



Dugotrajniji nožić od standardnog RB45 nožića.  
Odgovara svim 45mm RTY modelima.

- Lame plus durable que la RB45 classique.  
S'adapte à toutes les poignées OLFA 45 mm RTY !
- Langlebigere Klinge als die Standard-RB45.  
Passend für alle OLFA 45 mm-RTY-Griffe!
- Cuchilla más duradera en comparación con la estándar RB45.  
¡Se adapta a todos los mangos RTY de 45 mm de OLFA!

Dugotrajniji nožić od standardnog RB60 nožića.  
Odgovara svim 60mm RTY modelima.

- Lame plus durable que la RB60 classique.  
S'adapte à toutes les poignées OLFA 60 mm RTY !
- Langlebigere Klinge als die Standard-RB60.  
Passend für alle OLFA 60 mm-RTY-Griffe!
- Cuchilla más duradera en comparación con la estándar RB60.  
¡Se adapta a todos los mangos RTY de 60 mm de OLFA!

Broj rezova napravljen bez greške (neisečenih delova tkanine).  
(maksimum od 2.000 rezova je napravljeno na testiranju).

- Nombre de coupures réalisées sans produire une partie non découpée sur des tissus.  
(Un maximum de 2,000 coupes ont été effectuées pour le test.)
- Anzahl der Schnitte, ohne einen nicht geschnittenen Teil auf Stoffen zu produzieren.  
(Für den Test erfolgten maximal 2.000 Schnitte.)
- Número de cortes realizados sin producir una pieza no cortada en los paños.  
(Para la prueba, se realizaron un máximo de 2.000 cortes.)

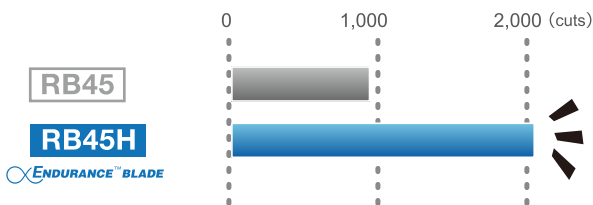

- \* OLFA interni test
- \* Opterećenje: 2.5kg (prosečno) \* Ručica za testiranje: RTY-2/C
- \* Materijal za sečenje: Preklapljeni 900mm široki i 0.2mm debeli pamučni pojasaevi
- \* U svakoj proizvodnji postoje tolerancije i varijacije proizvodnje.

\* Test interne OLFA \* Charge : 2,5 KGF(moyenne) \* Poignée pour le test : RTY-2/C  
\* Objet de coupe : popelines en coton pliées en quatre avec 900 mm de large et 0,2 mm d'épaisseur  
\* Il existe des tolérances de fabrication et des variations dans chaque lot de production.

\* OLFA interner Test \* Ladung: 2,5 KGF(Durchschnitt) \* Getesteter Griff: RTY-2/C  
\* Schneideobjekt: Gefaltetes und 900 mm breites und 0,2 mm dickes Baumwoll-Breitgewebe in vier Teilen  
\* Bei jeder Produktionscharge gibt es Fertigungstoleranzen und Variationen.

\* Prueba interna de OLFA \* Carga: 2,5 kgf (media) \* Mango para la prueba: RTY-2/C  
\* Objeto del corte: Paños de algodón de 900 mm de ancho y 0,2 mm de grosor plegados en cuatro  
\* Existen tolerancias y variaciones de fabricación en cada lote de producción.

Dužina rezova napravljena na tkanini sa jednim nožićem.

- Longueur des coupes effectuées sur le tissu avec la même charge.
- Länge der Schnitte an Stoffen bei gleichem Druck.
- Longitud de los cortes realizados en paños con la misma carga.

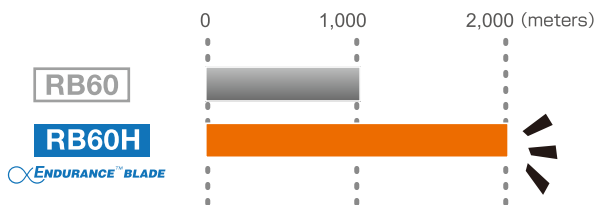

- \* OLFA interni test
- \* Opterećenje: 0.6kg (broj zasnovan na podatku da je RB60H nožiću bilo potrebno najmanje 0.6kg sile prilikom sečenja 2.000 metara bez ostavljanja neizrezanih delova).

\* Test interne OLFA  
\* Charge : 0,6 kgf (chiffre basé sur le fait que la RB60H nécessite au moins 0,6 kgf pour couper 2 000 mètres sans laisser de pièces non coupées)

\* Interner Test bei OLFA  
\* Druckkraft: 0,6 kgf (basierend auf Daten, die ergaben, dass der RB60H mindestens 0,6 kgf Druckkraft benötigt, um 2.000 Meter zu schneiden, ohne ungeschnittene Bereiche zurückzulassen)

\* Prueba interna OLFA  
\* Carga: 0,6 kgf (cifra basada en datos que muestran que el RB60H necesitaba al menos 0,6 kgf al cortar 2000 metros sin dejar piezas sin cortar)

RB45  
RB60

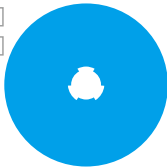

RB45H  
RB60H

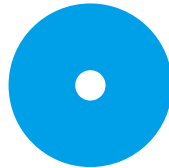

Nožići RB45H/RB60H sa okruglom rupom bolje se uklapaju sa rotacionim skalpelima i pružaju veću prijatnost prilikom korišćenja.

- Dotée d'un trou circulaire, la RB45H/RB60H est mieux adaptée aux lames rotatives OLFA pour offrir plus de convivialité et de confort aux adeptes du quilting.
- Mit einem runden Loch passt das RB45H/RB60H besser an die OLFA-Drehmesser und bietet Quiltern somit ganz neuen Komfort.
- Con un orificio redondo, el RB45H/RB60H se adapta mejor a los cortadores rotativos OLFA para proporcionar acolchados con un nivel de usabilidad superior.

# Lenjiri

Neklizajući, providni lenjiri sa brojevima i mernom mrežom koja je čitljiva i na svetlijim i na tamnijim materijalima.

## Règles de matelassage

Règle en acrylique avec surface dépolie antidérapante. Lignes de la grille lisibles à la fois sur les tissus de couleur claire et foncée.

## Quilt-Lineale

Rutschfest, mattierte Oberfläche Acryllineale. Lesbare Gitterlinien sowohl auf hellen als auch auf dunkelfarbenen Stoffen.

## Reglas de costura

Reglas acrílicas de superficie mate anti deslizantes. Líneas de cuadrícula legibles en telas con colores oscuros y claros.

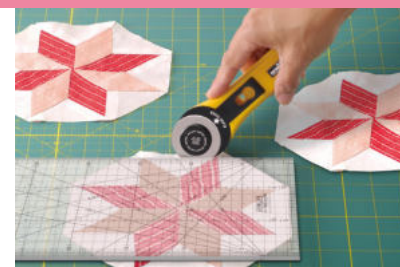

Lenjiri  
Art&Hobby - Ručni alati za razne namene

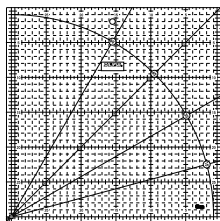

MQR-30x30

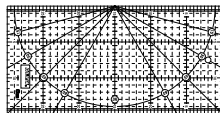

MQR-15x30

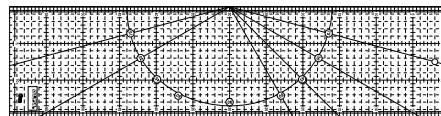

MQR-15x60



QR-1x12



QR-4S

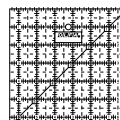

QR-6S

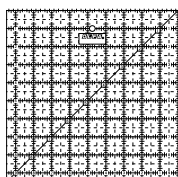

QR-9S

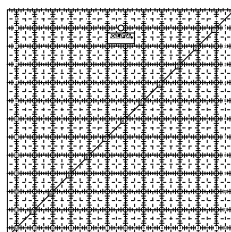

QR-12S

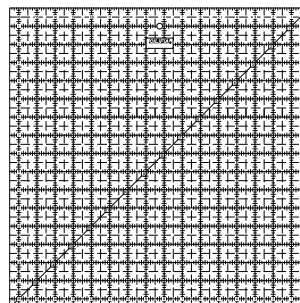

QR-16S

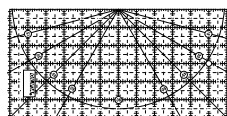

QR-6x12

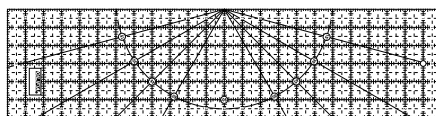

QR-6x24

### MQR-30x30

**PAT.**

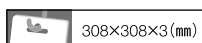

308x308x3 (mm)



6x8 (pcs.)

30cmx30cm

### MQR-15x30

**PAT.**

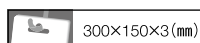

300x150x3 (mm)



6x8 (pcs.)

15cmx30cm

### MQR-15x60

**PAT.**

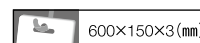

600x150x3 (mm)



6x8 (pcs.)

15cmx60cm

### QR-1x12

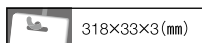

318x33x3 (mm)



12x20 (pcs.)

1(1/4)"x12.5"

### QR-4S

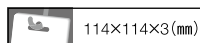

114x114x3 (mm)



6x10 (pcs.)

4.5"x4.5"

### QR-6S

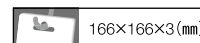

166x166x3 (mm)



6x10 (pcs.)

6.5"x6.5"

### QR-9S

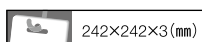

242x242x3 (mm)



6x8 (pcs.)

9.5"x9.5"

### QR-12S

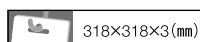

318x318x3 (mm)



6x4 (pcs.)

12.5"x12.5"

### QR-16S

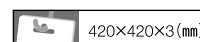

420x420x3 (mm)



6x2 (pcs.)

16.5"x16.5"

### QR-6x12

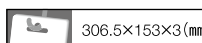

306.5x153x3 (mm)



6x8 (pcs.)

6"x12"

### QR-6x24

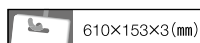

610x153x3 (mm)



6x4 (pcs.)

6"x24"

# Art&Hoby - Ručni alati za razne namene

Široka lepeza reznih alata koji odgovaraju raznim idejama, raznim materijalima i raznim radnim okruženjima.

## Autres outils manuels pour usage spécifique

Le large éventail d'outils de coupe les mieux adaptés pour chaque idée, chaque matériau de coupe, et chaque environnement de travail de coupe.

## Andere speziell angefertigte Handwerkzeuge

Das umfangreiche Sortiment an Schneidwerkzeugen, die am besten für jede Idee, jedes Schneidmaterial und jede Arbeitsumgebung passen.

## Otras herramientas manuales hechas a propósito

La amplia gama de las herramientas de corte que mejor se adapta a cada idea, cada material de corte y cada entorno de trabajo.



## AK-4



ONE-SIDED SHARPENING

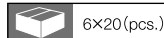
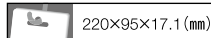

Premium art skalpel sa gumiranim (soft) držačem.

- Couteau d'art de qualité supérieure avec poignée molle
- Erstklassiges Kunstmesser mit weichem Griff
- Cortador artístico premium con mango suave

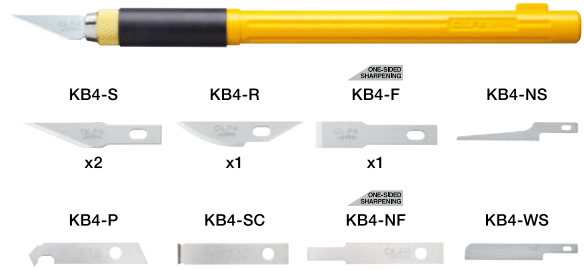

## KB4-S/100

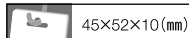

Ekonomično pakovanje sa 100 nožića.

- 100 lames dans un boîtier d'emballage économique
- 100 Klingen, die verbrauchsarm verpackt sind
- 100 cuchillas incluidas en un embalaje económico

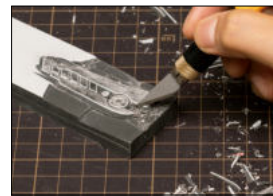

KB4-S



KB4-R



KB4-F



KB4-NF



KB4-SC



KB4-P

## AK-1



ACETONE RESISTANT



KB

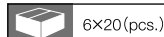
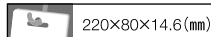

## AK-1/5B



ACETONE RESISTANT



KB

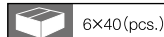
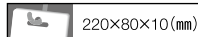

Osnovni art skalpel.

- Couteau d'art de base
- Einfaches Kunstmesser
- Cortador artístico básico



## AK-5



**KB-5x30** Needle x1



KB-5



220×65×16 (mm)



6×20 (pcs.)



## AK-5/5B



**KB-5x5**



KB-5



220×65×13 (mm)



6×40 (pcs.)

Oštar nožić pod uglom je idealan za precizno sečenje.  
Skladište za rezervne nožiče služi kao postolje kada se spoji sa poklopcem nožiča.

La lame à bout pointu est parfaite pour assurer la précision de coupe. La boîte de lame de rechange fonctionne comme un standish lorsqu'il est connecté au cache de la lame.

Die Klinge mit scharfer Spitze ist perfekt für präzises Schneiden. Der Ersatzklingenbehälter dient als Ständer, wenn er an der Klingendeckung befestigt ist.

La cuchilla afilada puntiaguda es perfecta para un corte de precisión. El estuche de la cuchilla de repuesto caso funciona como un soporte al conectarla a la cubierta de la cuchilla.



## ESK-1



**PAT.**



ESKB-1



220×80×35 (mm)



6×12 (pcs.)

Nožić sa segmentima pokriven plastikom i otvoren malom površinom samo na jednom čošku pogodan je za dečiju upotrebu.

Le couteau tout usage à lame cassable d'entrée de gamme pourrait être votre premier couteau tout usage!

Dieses Einsteiger-Universalmesser mit Abbrechklinge kann Ihr erstes Universalmesser sein!

Esta cuchilla multiusos básica desmontable podría ser su primera cuchilla multiusos!

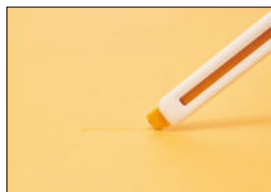

## TS-1



**TSB-1x3**



TSB-1



220×80×13 (mm)



6×20 (pcs.)

Neverovatan, iseca samo gornji list papira.  
Podešavanje dubine reza min-max.

Incredible, permet de ne couper que la feuille supérieure

Unglaublich, schneidet nur das obere Blatt

Incredible, corta únicamente la hoja superior





## TK-4/60

STAINLESS  
STEEL  
BLADE



221×196×65 (mm)



60×20 (pcs.)

## TK-4/32



639×235×9 (mm)



32×30 (pcs.)

Malih (džepnih) dimenzija, kompaktn, idealan za poklon sa mogućnošću štampe.

- Cutter compact et pratique
- Kompaktes und bequemes Schneidmesser
- Cúter compacto y útil



TK-4/60



TK-4/32



## TK-3M/24

STAINLESS  
STEEL  
BLADE



498×219×12 (mm)



24×30 (pcs.)

Malih (džepnih) dimenzija sa magnetom, idealan za poklon sa mogućnošću štampe.

- Couteau tactile magnétique
- Magnetisches Kontaktmesser
- Cortador magnético de bolsillo



## UTC-1

AUTO  
LOCK

FOR BOTH  
RIGHT- AND LEFT-  
HANDED USERS

PAT.



SKB-2/RSKB-2/HOB-2



220×80×25 (mm)



6×20 (pcs.)

Veoma jak skalpel sa trapezoidnim nožićem za široku primenu.

- Un couteau tout usage résistant pour une large gamme de tâches
- Ein leistungsstarkes Universalmesser für eine Vielzahl von Aufgaben
- Una potente cuchilla multiusos para una amplia gama de tareas



## HOK-1



HOB-1



220×95×21 (mm)



6×20 (pcs.)

Močni skalpel sa kukom.

- Cutter à crochet puissant
- Kraftvolles Hakenmesser
- Cortador de gancho potente



## MC-45



MCB-1



223×94×60 (mm)



6×10 (pcs.)

ONE-SIDED SHARPENING



MCB-1x6

## MC-45/2B



MCB-1



223×94×59.5 (mm)



6×10 (pcs.)

ONE-SIDED SHARPENING



MCB-1x2

Skalpel sa nožićem pod uglom od 45° za paspartue.

- Coupe oblique à 45°, idéal pour les encadrements
- 45° schräges Schneiden, großartig für Bilderhalterungen
- Corte oblicuo de 45° excelente para montajes de imágenes

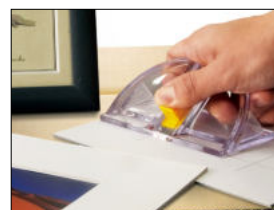
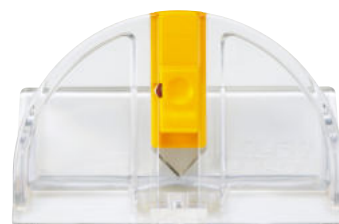

## MC-45/DX



MCB-1



553×93×67 (mm)



5×6 (pcs.)

ONE-SIDED SHARPENING



MCB-1x3

Napredni model «DX» sa lenjirom.

- Modèle perfectionné avec règle de repère
- Erweitertes Modell mit Führungslinéal
- Modelo avanzado con regla guía

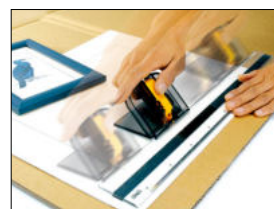

## PC-L



PB-800



220×80×23 (mm)



6×20 (pcs.)

ONE-SIDED SHARPENING



size

PB-800x3

Skalpel za struganje klirita i plastike sa skladištem za 2 rezervna nožića.

- Cutters en plastique avec 2 lames supplémentaires. Notation sur plaque en plastique pour découpe.
- Plastikmesser mit 2 extra Klingen. Zum Abbrechen auf Kunststoffplatte anritzen.
- Cortadores de plástico con 2 cuchillas adicionales. Raya placas de plástico para posteriormente romperlas.



## PC-S



**PB-450x3**



PB-450



220×80×17 (mm)



6×20 (pcs.)

Skalpel za struganje klirita i plastike sa skladištem za 2 rezervna nožića. Manji model.

- Cutters en plastique avec 2 lames supplémentaires. Notation sur plaque en plastique pour découpe.
- Plastikmesser mit 2 extra Klingen. Zum Abbrechen auf Kunststoffplatte anritzen.
- Cortadores de plástico con 2 cuchillas adicionales. Raya placas de plástico para posteriormente romperlas.

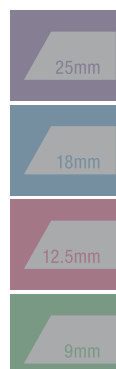
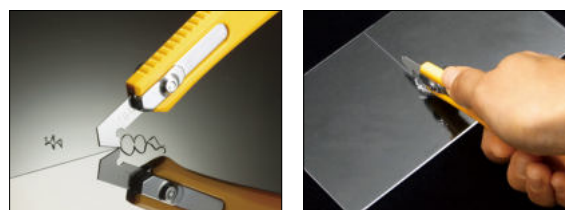

## SK-3



**SKB-2x2**



SKB-2/SKB-2S/SKB-2S-R/  
RSKB-2/HOB-2



220×80×20 (mm)



6×40 (pcs.)

Model sa trapezoidnim nožićem. Za levoruke i desnoruke.

- Contient 1 lame de rechange dans la poignée. Adapté aux droitiers et aux gauchers.
- Enthält 1 Ersatzklinge im Griff. Sowohl für Rechts- als auch für Linkshänder geeignet.
- Incluye 1 cuchilla de repuesto en el mango. Apta tanto para usuarios diestros como zurdos.



## CTN-1



**CTN-1**



CTB



160×63×8.2 (mm)



24×20 (pcs.)



CTN-1

## CTN-1/40



**CTN-1/40**



CTB



197×127×77 (mm)



40×12 (pcs.)

Skalpel za karton sa nožićem sa 6 segmenata.

- Cutter à carton avec lame sécable
- Kartonmesser mit Abknick-Klinge
- Cortador para cartón con cuchilla desglosable



CTN-1/40



## 45-C



**RB45**



RB45



240×115×27 (mm)



6×10 (pcs.)

Skalpel za tepihe i itisone.

- Cutter pour moquette/lino
- Teppich- / Linoleummesser
- Cortador de moqueta / lino

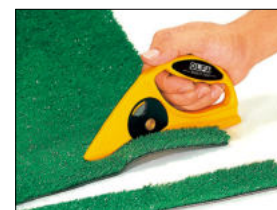

### CMP-1



OLFA COB-1x6



COB-1



220×95×25 (mm)



6×20 (pcs.)

Seče krugove u prečniku od 1-15cm.

- Permet de découper des cercles de 1 à 15 cm de diamètre
- Schneidet Kreise im Durchm. 1 - 15 cm
- Corta círculos en diámetros de 1 a 15 cm

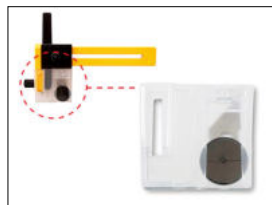

### CMP-1/DX



OLFA COB-1x11



COB-1



220×130×26 (mm)



6×20 (pcs.)

Seče krugove u prečniku od 1,6-22cm.

- Cutter rotatif à rochet de diamètre de 1,6 à 22 cm
- Knarrenkreismesser im Durchm. 1,6 - 22 cm
- Cortador con carrete que corta círculos de diámetro de 1,6 a 22 cm



### CK-1



CKB-1



220×50×11.2 (mm)



6×40 (pcs.)

Skapel za duborez i razne hobi poslove sa materijalima od drveta.

- Couteau d'artisanat pour la sculpture du bois et les activités de loisir
- Handwerksmesser für die Holzschnitzerei und Hobbyhandwerkskunst
- Cuchilla de manualidades para el tallado de madera y artesanías no profesionales



### CK-2



CKB-2



220×70×12.9 (mm)



6×40 (pcs.)

Skapel za kalemljenje, duborez i razne hobi poslove sa materijalima od drveta. Od nerđajućeg čelika.

- Modèle en acier inoxydable
- Edelstahlmodell
- Modelo de acero inoxidable





# Podloge za sečenje

Samolepljive OLFA podloge za sečenje napravljene su za upotrebu sa OLFA skalpelima, Art&Hoby kao i rotacionim skalpelima. Podloga štiti površinu na kojoj se seče i takođe produžava vek nožića.



## Tapis de coupe/Tapis rotatifs

Tapis de coupe auto-cicatrisant conçu par l'inventeur de la lame cassable, utilisation optimale avec les cutters OLFA, les couteaux d'art et les cutters rotatifs. Les tapis protègent les surfaces de coupe et améliorent également la durée de vie des lames.

## Schneidematten/Rotationsschneidematten

Selbstheilende Schneidematten, die vom Erfinder des Abbrechklingennessers entwickelt wurden und am besten mit OLFA-Schneidern, Kunstmessern und Rotationsschneidern verwendet werden. Die Matten schützen die Schneideoberflächen und erhöhen außerdem die Lebensdauer der Klingen.

## Alfombrillas de corte/alfombrillas giratorias

Alfombrillas de corte autorreparables diseñadas por el creador del cutter de hoja desmontable, utilizadas especialmente con cúteres OLFA, cuchillas para arte y cúteres giratorios. Las alfombrillas protegen las superficies de corte y también alargan la vida útil de las cuchillas.

## Podloge na preklapanje pogodne su za lako prenošenje i odlaganje. Dizajnirane su za ozbiljnije (heavy-duty) sečenje.

Le tapis Olefin, respectueux de l'environnement, est plus facilement transportable grâce à sa taille plus petite une fois plié. La taille des tapis repliables est idéale pour le transport et le rangement et ils sont conçus pour une coupe intensive.

Die umweltfreundliche Olefin-Matte ist dank ihrer kleineren und faltbaren Größe tragbarer. Zusammenklappbare Matten lassen sich gut tragen und verwahren und sind für das Schwerlastschneiden konstruiert.

Su menor tamaño plegado hace que esta estera Olefin ecológica sea más portátil. Las esteras plegables tienen el tamaño de transporte y almacenamiento ideal y han sido diseñadas para el corte industrial.

### FCM-A2



515x320x6.5 (mm)



6x4 (pcs.)

Podloga: (tokom korišćenja) 450mm x 620mm / (preključena) 450mm x 315mm

Tapis: (Pendant l'utilisation) 450mm x 620mm / (Une fois replié) 450mm x 315mm

Matte: (Beim Gebrauch) 450mm x 620mm / (Zusammengeklappt) 450mm x 315mm

Estera: (durante el uso) 450 mm x 620 mm / (plegada) 450 mm x 315 mm

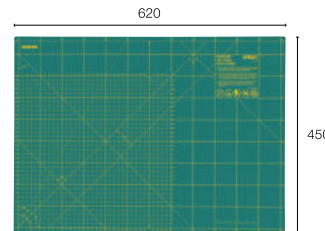

### FCM-A3



350x230x6.5 (mm)



6x8 (pcs.)

Podloga: (tokom korišćenja) 320mm x 450mm / (preključena) 320mm x 230mm

Tapis: (Pendant l'utilisation) 320mm x 450mm / (Une fois replié) 320mm x 230mm

Matte: (Beim Gebrauch) 320mm x 450mm / (Zusammengeklappt) 320mm x 230mm

Estera: (durante el uso) 320 mm x 450 mm / (plegada) 320 mm x 230 mm

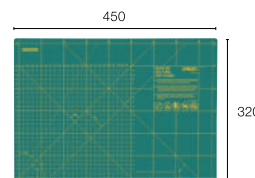
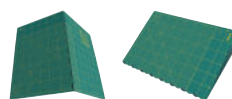

## 360° rotaciona podloga pogodna za modeliranje.

Tapis rotatif à 360° pour scrapbooking, créations en papier, matelassage et modélisation.

360°-Rotationsschneidematte für den Verschnitt von Büchern, Papierbasteleien, Quilten und Modellieren.

Alfombrilla giratoria, a 360°, para "scrapbooking", manualidades con papel, enguatao y modelado.

### RM-17S



462x442x7 (mm)



3x3 (pcs.)

17"x17"

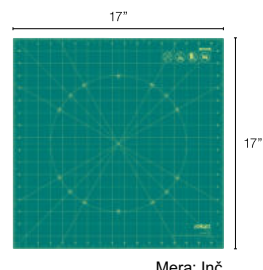
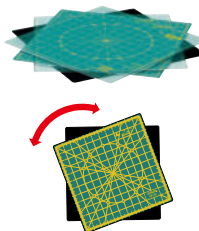

Mera: Inč

### RM-12S



341x320x7 (mm)



3x8 (pcs.)

12"x12"

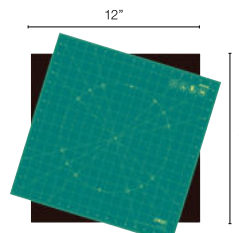
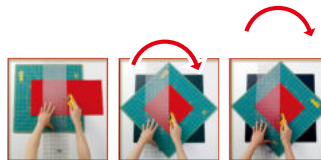

Mera: Inč

### RM-30x30

### RM-30x30-RC \*



320x320x7 (mm)



3x8 (pcs.)

30cmx30cm

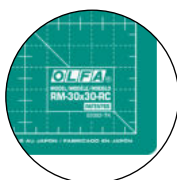

### RM-30x30-RC \*

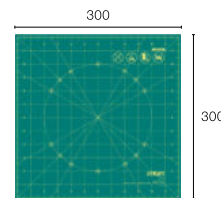

Mera: cm

Ekološka podloga za sečenje bez DEHP-a za Evropsko tržište.

Tapis de coupe sans DEHP, respectueux de l'environnement, conçu pour le marché européen.

Für den europäischen Markt konzipierte umweltfreundliche und DEHP-freie Schneidmatte.

Soporte para cortar libre de DEHP respetuoso con el medio ambiente diseñado para el mercado europeo.

debljina  
**2mm**



**Najpodbnije su za hobi i krojačke radove.  
Obe strane upotrebjive (cm/inč).**

Idéal pour le travail artisanal et les loisirs. Grilles sur les deux côtés (cm/pouce). Double face.

Die beste Wahl für Hobby- und Handwerksarbeiten. Gitter an beiden Seiten (cm/Zoll). Beidseitig.

Muy adecuada para trabajos artesanales y manualidades Cuadrículas en ambos lados (cm/pulgadas). Doble cara.

**CM-A1**  
**CM-A1-RC** \*

 940x630x2 (mm)  
92cmx61cm/36"x24"

 5x2 (pcs.)



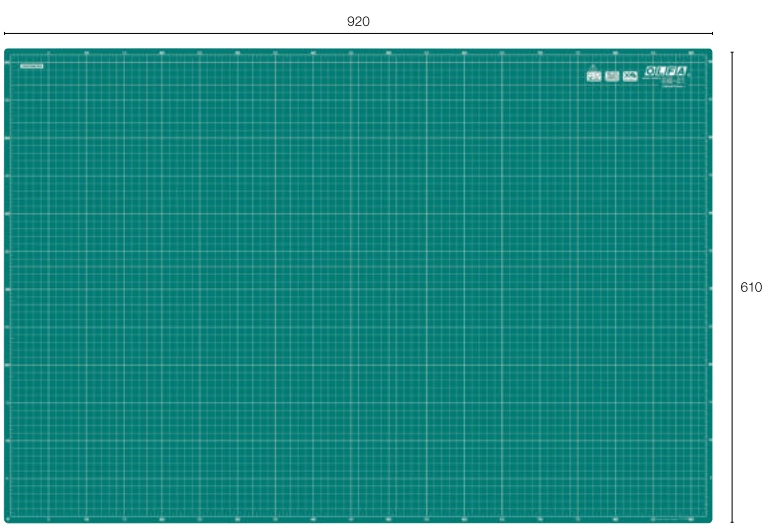

**CM-A2**  
**CM-A2-RC** \*

 600x430x2 (mm)  
60cmx43cm/24"x17"

 5x4 (pcs.)



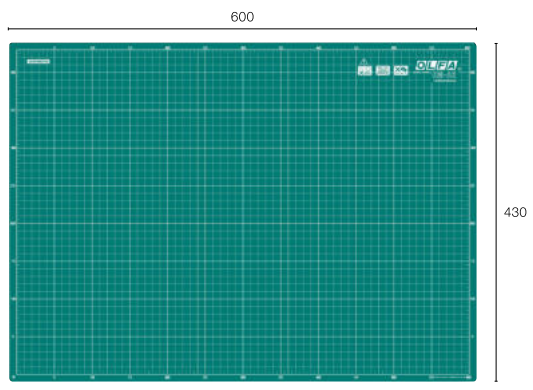

**CM-A3**  
**CM-A3-RC** \*

 430x300x2 (mm)  
43cmx30cm/17"x12"

 5x12 (pcs.)



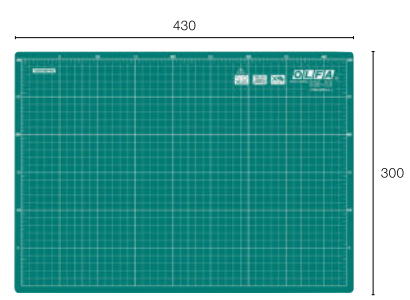

**CM-A4**  
**CM-A4-RC** \*

 300x210x2 (mm)  
30cmx21cm/12"x8"

 5x20 (pcs.)



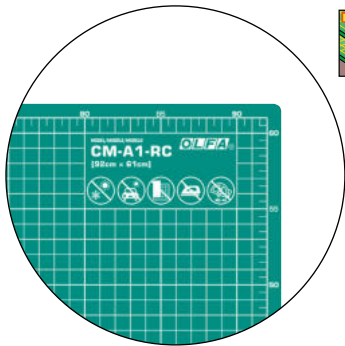
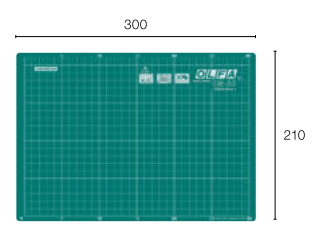

- CM-A1-RC** \*
- CM-A3-RC** \*
- CM-A2-RC** \*
- CM-A4-RC** \*

Ekološka podloga za sečenje bez DEHP-a za Evropsko tržište.

- | Tapis de coupe sans DEHP, respectueux de l'environnement, conçu pour le marché européen.
- | Für den europäischen Markt konzipierte umweltfreundliche und DEHP-freie Schneidmatte.
- | Soporte para cortar libre de DEHP respetuoso con el medio ambiente diseñado para el mercado europeo.

debljina  
**3mm**



**Deluks podloge za sečenje kao najbolja kombinacija sa našim nožićima i rotacionim skalpelima. Obostrano upotrebljiva.**

Tapis de coupe Deluxe pour la meilleure association avec nos couteaux et cutters rotatifs. Double face.

Deluxe-Schneidematte für die beste Kombination mit unseren Messern und Rotationschneidern. Beidseitig.

Alfombrilla de corte de lujo para obtener la mejor combinación con nuestras cuchillas y nuestros cúteres giratorios. Doble cara.

**NCM-L**

**NCM-L-RC** \*

 900x620x3 (mm)

 5pcs. (pcs.)

90cmx62cm/35"x24"

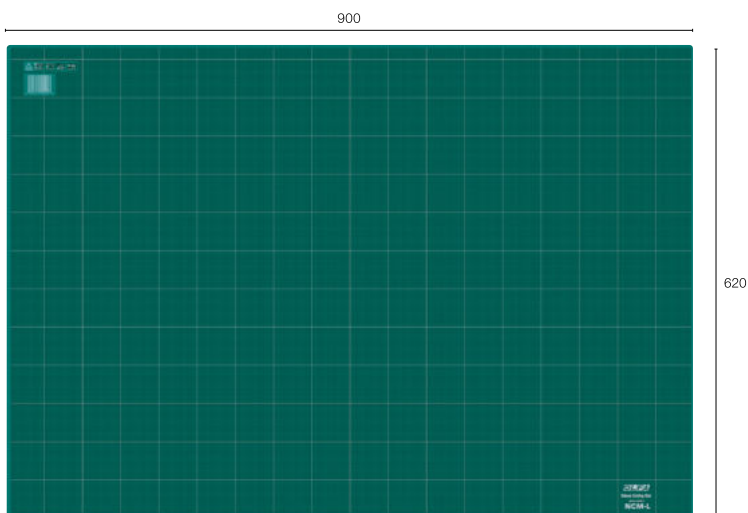

**NCM-M**

**NCM-M-RC** \*

 710x450x3 (mm)

 10pcs. (pcs.)

62cmx45cm/24"x18"

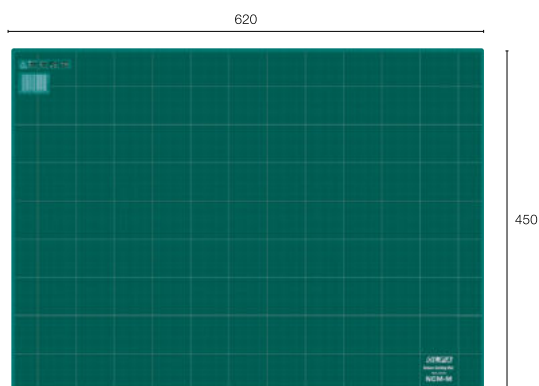

**NCM-S**

**NCM-S-RC** \*

 533x300x3 (mm)

 20pcs. (pcs.)

45cmx30cm/18"x12"

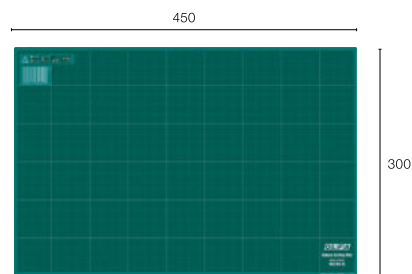

**NCM-L-RC** \*

**NCM-M-RC** \*

**NCM-S-RC** \*

**Ekološka podloga za sečenje bez DEHP-a za Evropsko tržište.**

Tapis de coupe sans DEHP, respectueux de l'environnement, conçu pour le marché européen.

Für den europäischen Markt konzipierte umweltfreundliche und DEHP-freie Schneidmatte.

Soporte para cortar libre de DEHP respetuoso con el medio ambiente diseñado para el mercado europeo.



debljina  
1.5mm



Dizajnirane za rotacione skalpele. Samolečiva podloga sa tri sloja.

Conçu pour être utilisé avec nos cutters rotatifs. Tapis triple couche auto-cicatrisants. Double face.

Für die Verwendung mit unseren Rotationschneidern vorgesehen. Selbstheilende dreilagige Matten. Beidseitig.

Diseñada para ser usada con nuestros cúteres giratorios. Alfombrillas de tres capas autorreparables. Doble cara.

RM-MG



630x940x1.5 (mm)



5 (pcs.)

92cmx61cm/36"x24"

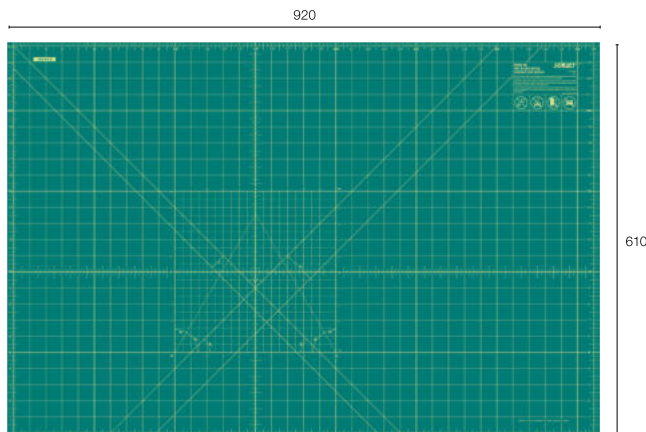

RM-SG



470x632x1.5 (mm)



5x4 (pcs.)

60cmx45cm/24"x18"

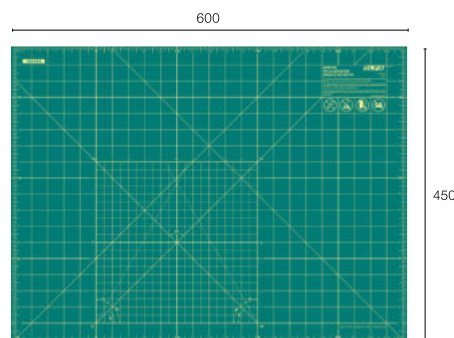

RM-CG



320x470x1.5 (mm)



5x8 (pcs.)

45cmx30cm/18"x12"

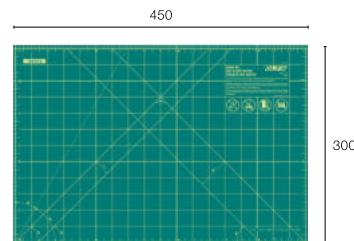

debljina  
1.5mm



Podloga sa klipsama za njihovo spajanje kako bi se dobila veća površina za sečenje.

Jeu de tapis conçu pour offrir de plus grandes surfaces de travail

Ein Set an Matten, die dafür vorgesehen sind, zu größeren Arbeitsflächen verbunden zu werden

Juego de alfombrillas diseñadas para cubrir superficies de trabajo más grandes

RM-CLIPS/3



940x608x15 (mm)



1x2 (pcs.)

180cmx90cm/70"x35"

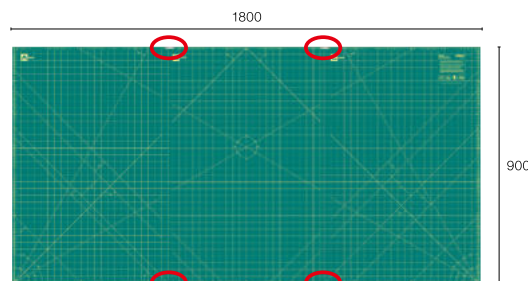
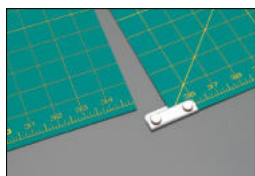

RM-CLIPS/2



940x605x12 (mm)



1x3 (pcs.)

180cmx60cm/70"x24"

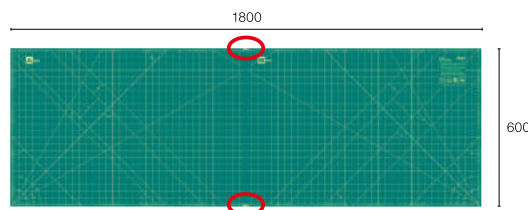



**RM-IC-M**  
**RM-IC-M-RC** \*

630x940x1.5(mm)

5x2 (pcs.)

92cmx61cm/36"x24"

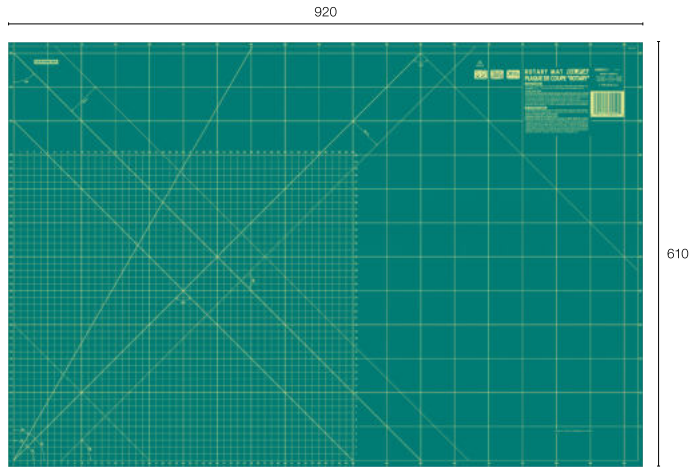

**RM-IC-S**  
**RM-IC-S-RC** \*

470x632x1.5(mm)

5x4 (pcs.)

60cmx45cm/24"x18"

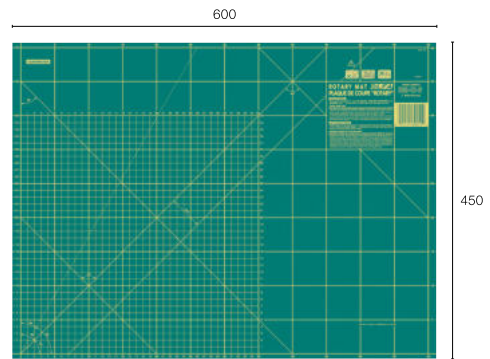

**RM-IC-C**  
**RM-IC-C-RC** \*

320x470x1.5(mm)

5x8 (pcs.)

45cmx30cm/18"x12"

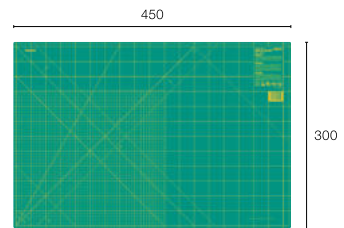

**RM-IC-C/PIK**  
**RM-IC-C-RC/PIK** \*

320x470x1.5(mm)

5x8 (pcs.)

45cmx30cm/18"x12"

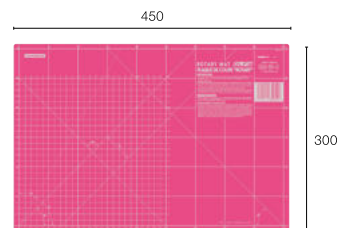

**RM-IC-C/AQA**  
**RM-IC-C-RC/AQA** \*

320x470x1.5(mm)

5x8 (pcs.)

45cmx30cm/18"x12"

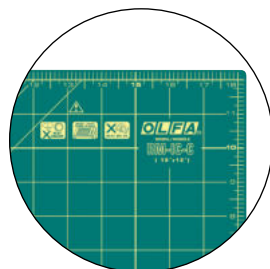
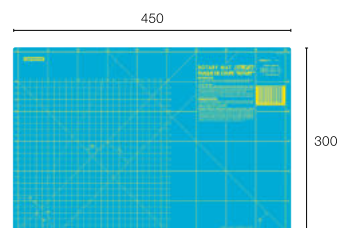

**RM-IC-M-RC** \* **RM-IC-S-RC** \* **RM-IC-C-RC** \*  
**RM-IC-C-RC/PIK** \* **RM-IC-C-RC/AQA** \*

Ekološka podloga za sečenje bez DEHP-a za Evropsko tržište.

- Tapis de coupe sans DEHP, respectueux de l'environnement, conçu pour le marché européen.
- Für den europäischen Markt konzipierte umweltfreundliche und DEHP-freie Schneidmatte.
- Soporte para cortar libre de DEHP respetuoso con el medio ambiente diseñado para el mercado europeo.



# Stalci za izlaganje - Štenderi

**DR-8**

SIZE: 640x370x1110 (mm)



**DR-14**

SIZE: 360x260x730 (mm)



**DR-1**

SIZE: 700x400x1730 (mm)



# Štampanje Logotipa

**SK-15**

Dimenzije površine za štampu: **W40xH10mm**



**BN-L**

Dimenzije površine za štampu: **W82xH13mm**



**MT-1**

Dimenzije površine za štampu:  
(A) Telo: **W40xH5.5mm**  
(B) Klipsa: **W22xH8mm**



**SK-4**

Dimenzije površine za štampu: **W50xH5mm**



**TK-4**

Dimenzije površine za štampu:  
(A) Napred: **W21xH8mm**  
(B) Nazad: **W35xH27mm**

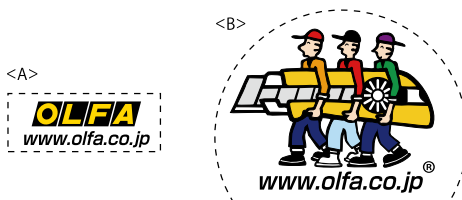

**TK-3**

Dimenzije površine za štampu: **W15xH6mm**



**L-1**

Dimenzije površine za štampu: **W27xH7mm**



\* Postoji još mnogo proizvoda sa mogućnošću štampe. \* Metode štampanja variraju od modela do modela.

# REZERVNI NOŽIČI

LAMES DE RECHANGE | ERSATZKLINGEN | CUCHILLAS DE REPUESTO

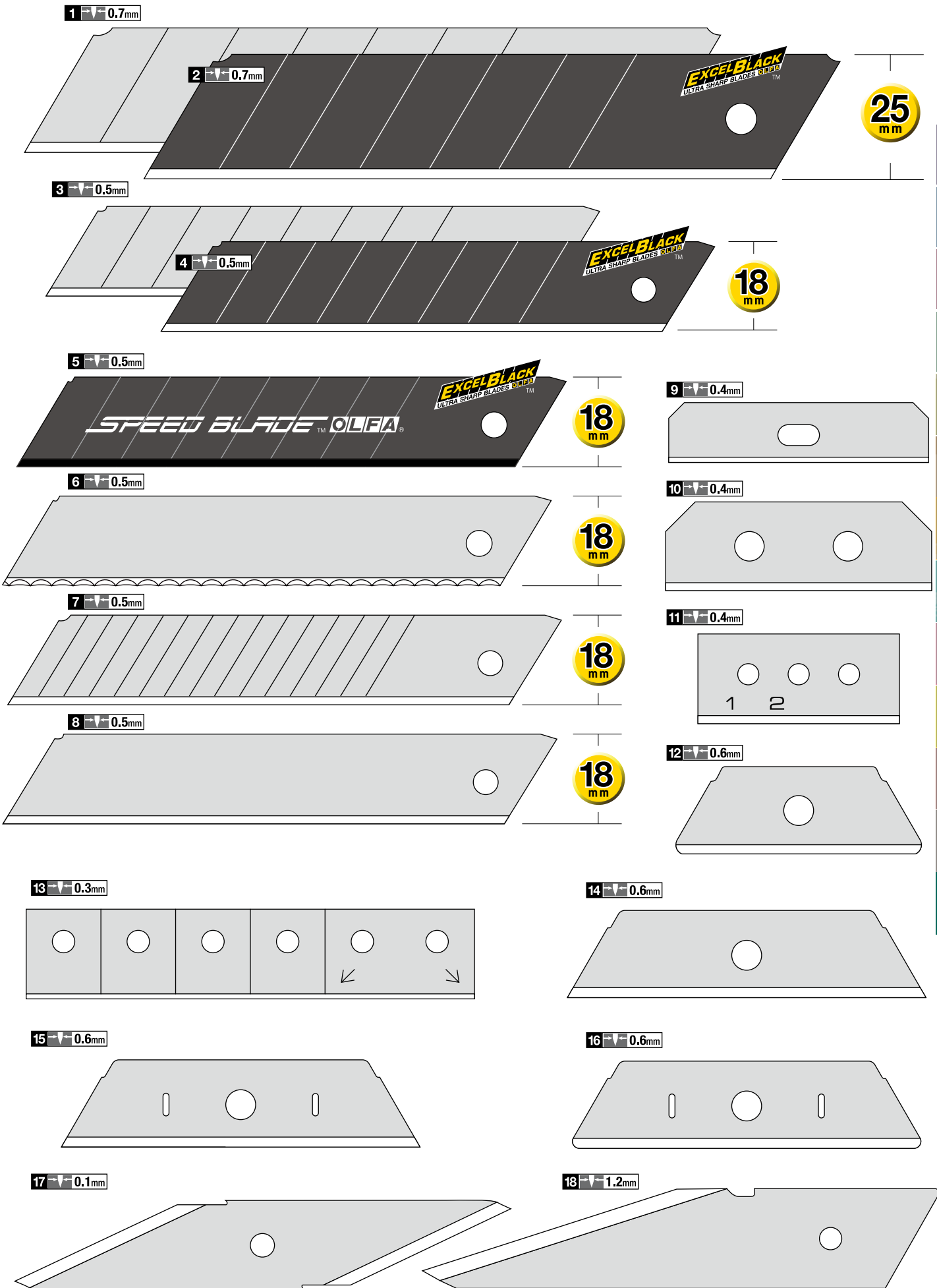



# REZERVNI NOŽIČI

| LAMES DE RECHANGE | ERSATZKLINGEN | CUCHILLAS DE REPUESTO

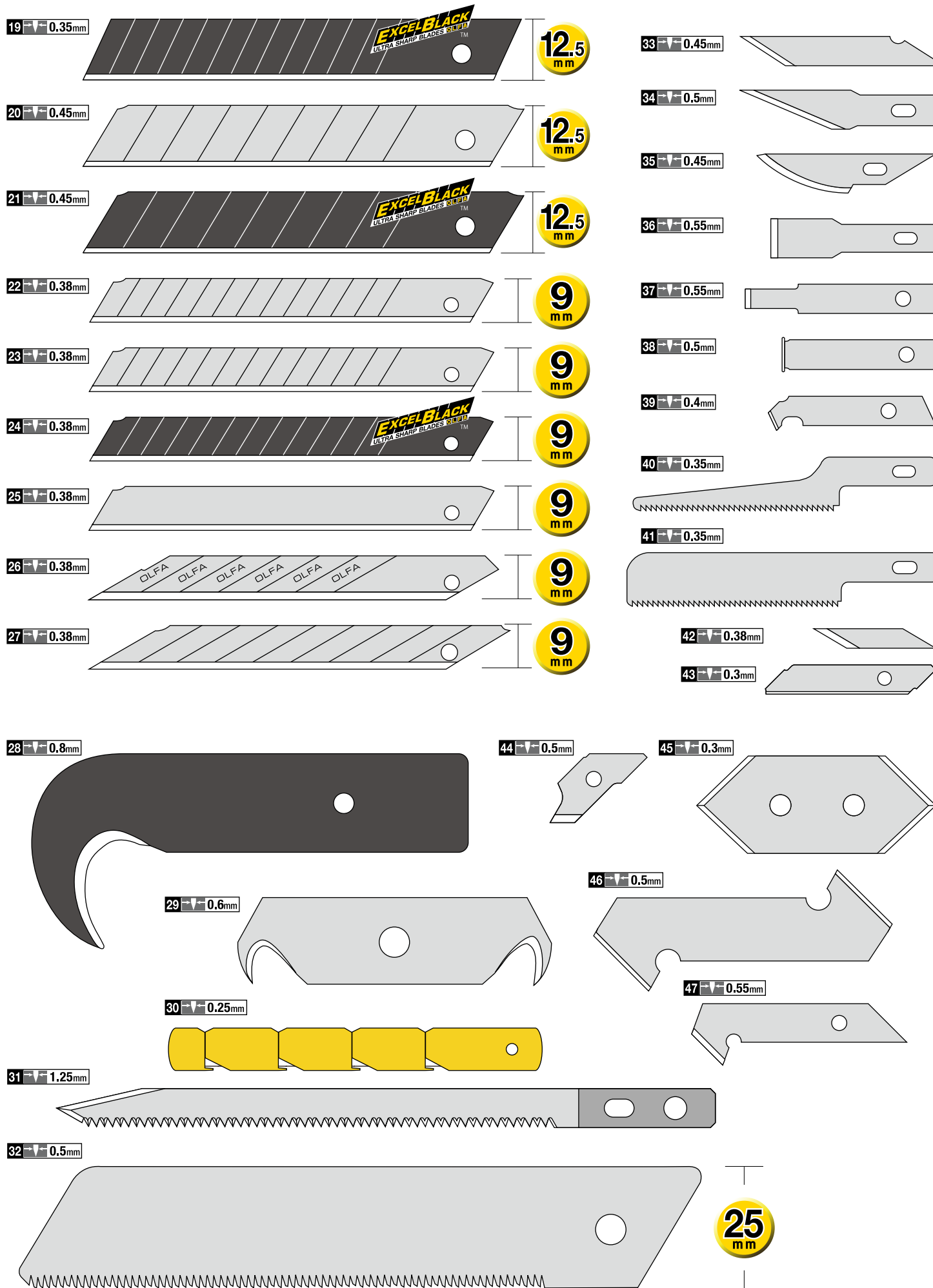

48  $\pm 0.35\text{mm}$

49  $\pm 0.35\text{mm}$

50  $\pm 0.35\text{mm}$

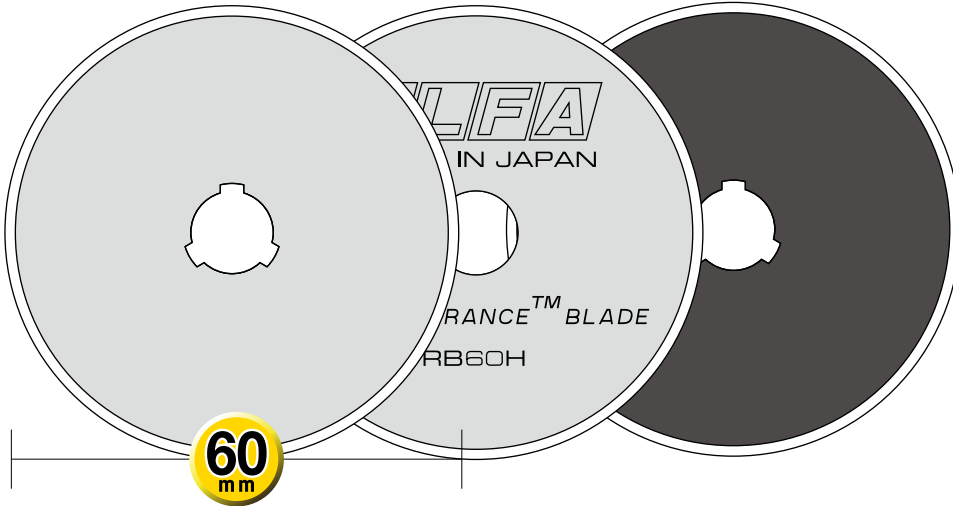

60 mm

55  $\pm 0.3\text{mm}$

56  $\pm 0.3\text{mm}$

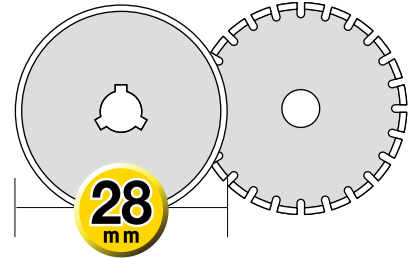

28 mm

57  $\pm 0.3\text{mm}$

58  $\pm 0.3\text{mm}$

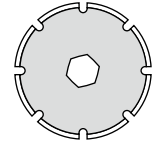
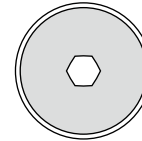

18 mm

18 mm

51  $\pm 0.3\text{mm}$

52  $\pm 0.3\text{mm}$

53  $\pm 0.4\text{mm}$

54  $\pm 0.4\text{mm}$

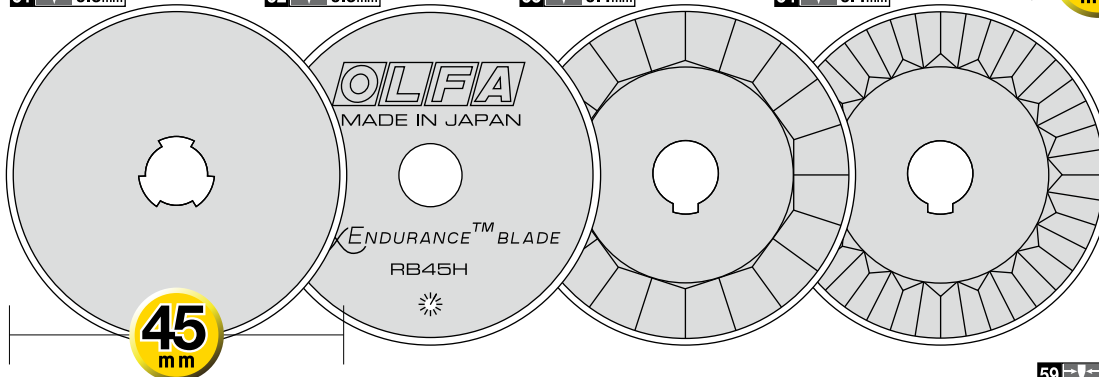

45 mm

60  $\pm 0.5\text{mm}$

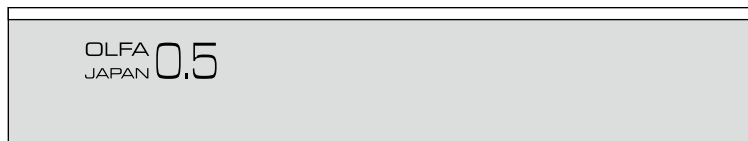

61  $\pm 0.8\text{mm}$



59  $\pm 0.45\text{mm}$



62  $\pm 0.45\text{mm}$



63  $\pm 0.6\text{mm}$

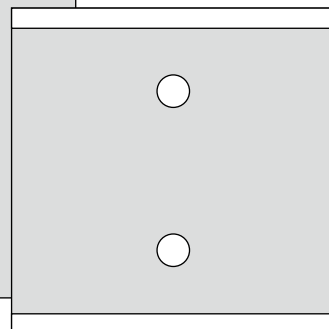

64  $\pm 0.7\text{mm}$

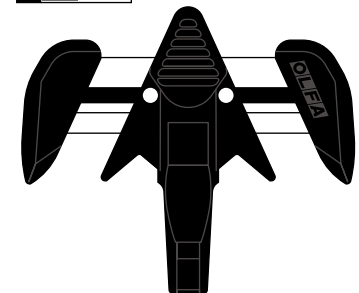

65  $\pm 0.25\text{mm}$



66  $\pm 0.25\text{mm}$



**Broj modela**

 | Numéro du Modèle  
 | Modell Nummer  
 | Numero de Modelo

**Pakovanje**

 | Emballage  
 | Verpackung  
 | Embalaje

**Sadržaj pakovanja**

 | Contenu  
 | Kartoninhalt  
 | Contenido

**Pakovanja u kutiji**











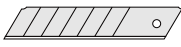























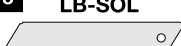



 | Contenu de Carton  
 | Kartoninhalt  
 | Contenido de Embalaje

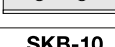









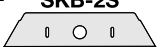

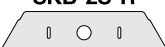

















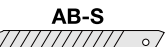



**Blister pakovanje**  
 | Emballage Blister  
 | Blister Packung  
 | Presentado en Blister

**Plast. kutijica**  
 | Étui Plastique  
 | Kunststoffbox  
 | Caja de Plástico

**Plast. kesica**  
 | Sachet Plastique  
 | Kunststoffbeutel  
 | Bolsa de Plástico

**Papirna kutija**  
 | Boîte en papier  
 | Papierverpackung  
 | Caja de papel

Slika modela	Appearance / Aussehen / Apariencia	Pakovanje	Sadržaj pakovanja	Pakovanja u kutiji	Koristi	Application / Anwendung / Aplicación
1 	HB	HB-5B		5	6x20	H-1, NH-1, XH-1, XH-AL, HSW-1
		HB-20		20	6x10	
2 	HBB	HBB-5B		5	6x20	
3 	LB	LB-6B		6	6x40	CL, OL, SL-1, ML, L-1, L-1/green, L-2, L-3, XL-2, NL-AL, EXL, BN-L, BN-AL, PL-1, NOL-1, L-5, L5-AL, L-7, L7-AL, MXP-L, MXP-AL, LTD-L, LTD-AL, DL-1, CMP-2, XSR-200, XSR-300, XSR-600
		LB-10		10	6x40	
		LB-10B		10	6x20	
		LB-30B		30	6x6	
		LB-50		50	6x10	
		LB-50B		50	6x6	
4 	LBB	LBB-10		10	6x40	CL, OL, SL-1, ML, L-1, L-1/green, L-2, L-3, XL-2, NL-AL, EXL, BN-L, BN-AL, PL-1, NOL-1, L-5, L5-AL, L-7, L7-AL, MXP-L, MXP-AL, LTD-L, LTD-AL, DL-1, CMP-2
		LBB-10B		10	6x20	
		LBB-30B		30	6x6	
		LBB-50		50	6x10	
5 	LFB	LFB-5B		5	6x20	
6 	LWB	LWB-3B		3	6x20	OL, SL-1, ML, L-1, L-1/green, L-2, XL-2, NL-AL, EXL, BN-L, BN-AL, PL-1, NOL-1, L-5, L5-AL, L-7, L7-AL, MXP-L, MXP-AL, LTD-L, LTD-AL
7 	LBD	LBD-10		10	6x40	CL, OL, L-1, L-1/green, L-2, L-3, XL-2, NL-AL, EXL, BN-L, BN-AL, PL-1, NOL-1, L-5, L5-AL, L-7, L7-AL, MXP-L, MXP-AL, LTD-L, LTD-AL, DL-1, CMP-2
		LBD-50		50	6x10	
8 	LB-SOL	LB-SOL-10		10	6x40	CL, OL, SL-1, ML, L-1, L-1/green, L-2, XL-2, NL-AL, EXL, BN-L, BN-AL, PL-1, NOL-1, L-5, L5-AL, L-7, L7-AL, MXP-L, MXP-AL, LTD-L, LTD-AL
9 	SKB-7	SKB-7/10B		10	6x40	SK-7, SK-7/green
10 	SKB-8	SKB-8/10B		10	6x40	SK-8
11 	SKB-10	SKB-10/10B		10	6x40	SK-10
12 	RSKB-2	RSKB-2/5		5	6x40	SK-6, SK-3, SK-4, SK-4/green, SK-5, SK-9, UTC-1
13 	CTB	CTB-5		5	24x20	CTN-1
14 	SKB-2	SKB-2/5B		5	6x40	SK-4, SK-4/green, SK-5, SK-9, SK-3, UTC-1

Slika modela	Appearance / Aussehen / Apariencia	Pakovanje	Sadržaj pakovanja	Pakovanja u kutiji	Koristi	Application / Anwendung / Aplicación
15 	SKB-2S	SKB-2S/10B		10	6x40	SK-12, SK-4, SK-4/green, SK-5, SK-9, SK-3
		SKB-2S-R/10B		10	6x40	
16 	SKB-2S-R	SKB-2S-R/10B		10	6x40	
17 	CKB-1	CKB-1		2	6x40	CK-1
18 	CKB-2	CKB-2		2	6x40	CK-2
19 	FWB	FWB-10		10	6x40	FWP-1
20 	MTB	MTB-10B		10	6x40	MT-1, XMT-1, CS-5
21 	MTBB	MTBB-10B		10	6x40	
22 	AB	AB-6		6	10x60	180Black, SVR-1, SVR-2, 300, A-2, A-3, S, SPC-1, ES-1/green, NA-1, A-5, PA-2, XA-1, DA-1, A-1
		AB-10		10	6x40	
		AB-10B		10	6x40	
		ASB-10		10	12x60	
		AB-50		50	6x20	
		AB-50B		50	6x20	
23 	AB-S	AB-10S		10	6x40	
		AB-50S		50	6x20	
24 	ABB	ASBB-10		10	12x60	
		ABB-10B		10	6x40	
		ABB-50		50	6x20	
25 	AB-SOL	AB-SOL-50		50	6x20	180Black, SVR-1, SVR-2, 300, A-2, S, SPC-1, ES-1/green, NA-1, A-5, XA-1, A-1
26 	SAB	SAB-10		10	10x60	SAC-1, A-1
		SAB-10B		10	6x40	
27 	DKB	DKB-5		5	100x10	



**Broj modela**

 | Numéro du Modèle  
 | Modell Nummer  
 | Numero de Modelo

**Pakovanje**

 | Emballage  
 | Verpackung  
 | Embalaje

**Sadržaj pakovanja**

 | Contenu  
 | Kartoninhalt  
 | Contenido

**Pakovanja u kutiji**

 | Contenu de Carton  
 | Kartoninhalt  
 | Contenido de Embalaje

**Blister pakovanje**

 | Emballage Blister  
 | Blister Packung  
 | Presentado en Blister

**Plast. kutijica**

 | Étui Plastique  
 | Kunststoffbox  
 | Caja de Plástico

**Plast. kesica**

 | Sachet Plastique  
 | Kunststoffbeutel  
 | Bolsa de Plástico

**Papirna kutija**

 | Boîte en papier  
 | Papierverpackung  
 | Caja de papel

Slika modela	Appearance / Aussehen / Apariencia	Pakovanje	Sadržaj pakovanja	Pakovanja u kutiji	Koristi	Application / Anwendung / Aplicación
28 	HOB-1		1	6x40	HOK-1	
29 	HOB-2/5		5	24x10	SK-4/HOK, SK-4, SK-4/green, SK-5, SK-9, SK-3, UTC-1	
30 	ESKB-1/2B		2	6x40	ESK-1	
31 	SWB-5/1B		1	10x12	CS-5	
32 	HSWB-1/1B		1	6x20	HSW-1, XH-1, XH-AL, H-1, NH-1	
33 	KB		25	6x40	AK-1, AK-4	
34 	KB4-S/5		5	6x40	AK-4	
	KB4-S/100		100	10x5		
35 	KB4-R/5		5	6x40		
36 	KB4-F/5		5	6x40		
37 	KB4-NF/5		5	6x40		
38 	KB4-SC/2		2	6x40		
39 	KB4-P/5		5	6x40		
40 	KB4-NS/3		3	6x40		
41 	KB4-WS/3		3	6x40		
42 	KB-5/30B		30	6x40		
43 	TSB-1		5	6x40	TS-1	
44 	COB-1		15 (5x3)	6x40	CMP-1, CMP-1/DX	
45 	MCB-1		5	6x40	MC-45, MC-45/DX	
46 	PB-800		3	6x40	PC-L	
47 	PB-450		5	6x40	PC-S	

Slika modela	Appearance / Aussehen / Apariencia	Pakovanje	Sadržaj pakovanja	Pakovanja u kutiji	Koristi	Application / Anwendung / Aplicación
48 	RB60-1		1	6x40	RTY-3/G, RTY-3/DX	
49 	RB60H-1		1	3x40	RTY-3/G, RTY-3/DX	
50 	CHB-1		1	6x20	CHN-1	
51 	RB45-1		1	6x80	RTY-2/G, RTY-2/DX, RTY-2/NS, RTY-2/C, RTY-2C/YEL, RTY-2C/PIK, 45C	
	RB45-10		10	6x10		
52 	RB45H-1		1	6x20		
53 	WAB45-1		1	6x40	RTY-2/DX	
54 	PIB45-1		1	6x40		
55 	RB28-2		2	6x80	RTY-1/C, PRC-3/C	
	RB28-10		10	6x10		
56 	PRB28-2		2	6x40		
57 	RB18-2		2	6x80	CMP-3, RTY-4, PRC-2	
58 	PRB18-2		2	6x80	PRC-2, RTY-4	
59 	TB-45		4	6x40	T-45	
60 	BS-10B		10	6x20	XSR-200, XSR-300, XSR-600	
61 	BS08-6B		6	6x20		
62 	BSF-6B		6	6x10		
63 	BTB-1		3	6x40	BTC-1	
64 	SKB-16/10		10	6x10	SK-16	
65 	GSB-1S		30	6x6	GSR-1, GSR-2	
66 	GSB-2S/6B		6	6x40	GSR-2	

**OLFA**®  
THE ORIGINATOR SINCE 1956

MANUFACTURED BY  
**OLFA CORPORATION**  
MANUFACTURER AND EXPORTER

Higashi-Nakamoto 2-11-8, Higashinari-Ku,  
OSAKA 537-0021, JAPAN

Phone: +81-(0)6-6972-8104  
F a x: +81-(0)6-6972-7400  
<https://www.olfa.co.jp/en/>



OLFA reserves the right to discontinue the sale of any products and to change the specification without prior notice to you or any other third party.  
OLFA shall not be liable for any claims or damages arising in connection with products sold prior to such change being implemented.

Entire contents copyright OLFA CORPORATION All rights reserved. OLFA®, X-Design® and SPEED BLADE® are registered trademarks of OLFA CORPORATION